

*Full Environmental Assessment Form Part 1*  
**Gas Land Petroleum – Route 9D**  
123 – 125 New Hamburg Road  
2357, 2361 – 2365 NYS Route 9D  
Town of Wappinger  
Dutchess County, New York



Issued: January 9, 2020  
Revised July 30, 2020  
Revised October 13, 2020  
Revised February 16, 2021  
Revised March 22, 2021  
Revised May 17, 2021  
Revised July 16, 2021

Prepared for:

Gas Land Petroleum, Inc.  
3 Ohioville Road  
New Paltz, New York 12561

Prepared by:

Chazen Engineering, Land Surveying &  
Landscape Architecture Co., D.P.C.  
21 Fox Street Suite 201  
Poughkeepsie, NY 12601  
845-454-3980



## TABLE OF CONTENTS

### PROJECT NARRATIVE

1.0	PROJECT DESCRIPTION.....	1
2.0	ENVIRONMENTAL ASSESSMENT .....	1
2.1	LAND USE AND ZONING .....	1
2.1.1	Land Use.....	1
2.1.2	Town of Wappinger Comprehensive Plan.....	2
2.1.3	Town of Wappinger Zoning.....	4
2.1.4	Dutchess County Greenway Compact Program.....	12
2.2	SOILS AND WATER RESOURCES .....	15
2.2.1	Soils .....	15
2.2.2	Water Resources .....	15
2.3	UTILITIES.....	15
2.3.1	Water and Wastewater .....	15
2.3.2	Stormwater .....	16
2.3.3	Solid Waste.....	17
2.4	TRAFFIC AND PARKING .....	17
2.5	ENDANGERED, THREATENED AND RARE SPECIES AND SIGNIFICANT HABITAT .....	18
2.6	HISTORIC AND ARCHEOLOGICAL RESOURCES .....	19

### FULL ENVIRONMENTAL ASSESSMENT FORM PART 1 FORM

## FIGURES

- Figure 1: USGS Location Map
- Figure 2: Orthophoto Tax Map
- Figure 3: Land Use Map
- Figure 4: Zoning Map
- Figure 5: Soils Map
- Figure 6: Wetland and Stream Map
- Figure 7: NYSDEC Environmental Resource Map
- Figure 8: NYSOPRHP Cultural Resource Information System (CRIS) Map
- Figure 9: Scenic and Aesthetic Resources Map

## ATTACHMENTS

- Attachment A: Table 1 – *Project Density Loading Rates & Design Sewage Flow Rates*, from the Suffolk County Department of Health Services
- Attachment B: US Fish & Wildlife Service (USFWS) Information for Planning and Consultation (IPAC)
- Attachment C: New York State Department of Environmental Conservation (NYSDEC) Information
- Attachment D: New York State Office of Parks, Recreation and Historic Preservation (NYSORPHP) Information
- Attachment E: Typical Underground Petroleum Storage Tank Drawing

Note: Site Plan Set submitted separately.

## PROJECT NARRATIVE

---

*Chazen Project #51807.00*

*January 9, 2020  
Revised July 30, 2020  
Revised October 13, 2020  
Revised February 16, 2021  
Revised March 22, 2021  
Revised May 17, 2021  
Revised July 16, 2021*



## 1.0 PROJECT DESCRIPTION

The Applicant, Gas Land Petroleum, Inc., proposes to develop a gasoline filling station (four pumps with eight fueling stations), a 3,630 square foot (SF) convenience store and three one-bedroom apartments on the 2<sup>nd</sup> floor) in a single 7,260 SF building with 32 parking spaces (including four parking spaces at the fueling stations and six reserved for the residences) on a 1.79-acre (ac) site located at 123 – 125 New Hamburg Road and 2357 and 2361 – 2365 NYS Route 9D in the Town of Wappinger (Figures 1 and 2). The proposed project is located within the Hamlet Mixed Use (HM) Zoning District and the action requires a site plan approval from the Planning Board and two special permits for the gasoline filling station (pursuant to §240-81.7) and for permission to use the building as a mixed use (pursuant to §240-52). The project site<sup>1</sup> is comprised of five tax parcels, including: 135689-6157-01-048643 (0.21 ac), 135689-6157-01-057642 (0.20 ac), 135689-6157-01-057654 (0.69 ac), 135689-6157-01-059643 (0.14 ac), and 135689-6157-01-040637-0000 (0.55 ac). The project site is currently occupied by three residential homes, a multi-family residence, single apartment, a garage and a bar comprising approximately 10,945 SF total. As part of the proposed action, these buildings would be demolished and the lot would be consolidated to form one tax parcel, which requires a subdivision approval from the Planning Board.

The FEAF Form Part 1 was completed utilizing the NYSDEC EAF Mapper. The EAF Mapper tool sometimes indicates limited availability for certain digital data. This narrative provides clarification for certain responses and/or reference used for the responses.

## 2.0 ENVIRONMENTAL ASSESSMENT

### 2.1 LAND USE AND ZONING

#### 2.1.1 Land Use

The project site is located on the north side of NYS Route 9D in the Hamlet of Hughsonville. The Land Use Map (Figure 3) shows land uses within 1,000 feet of the site. Uses in the vicinity of the project site include commercial uses clustered around the intersection of NYS Route 9D and New Hamburg Road. The Hughsonville Fire Station is located south of the site off Old Hopewell Road. Residential development in the vicinity of the site generally features detached single-, two-, and three-family homes in a suburban setting. The proposed development of the site with a fueling station with a convenience store and three one-bedroom apartments on the second floor would serve residents, employees of nearby businesses, and visitors to the area, and is consistent with Hamlet-style land uses located at the intersection of NYS Route 9D and New Hamburg Road. Six parking spaces have been provided and dedicated for the proposed residential apartment units.

---

<sup>1</sup> Tax parcels: 135689-6157-01-048643 (0.21 ac), 135689-6157-01-057642 (0.20 ac), 135689-6157-01-057654 (0.69 ac), and 135689-6157-01-059643 (0.14 ac) are owned by Charles Conklin and 135689-6157-01-040637-0000 (0.55 ac) is owned by Gas Land Petroleum, Inc.

### 2.1.2 Town of Wappinger Comprehensive Plan

The Town of Wappinger adopted its current Comprehensive Plan on September 27, 2010. The Hughsonville Hamlet is featured prominently within the Plan and is the subject of many recommendations, including methods to enhance community character, increase residential and mixed use development, improve traffic flow, and expand municipal water and sewer service.

The Hughsonville Hamlet is identified in the Introduction as an issue and opportunity for the Town with regard to Community Appearance and Character where it states on Page 5, “The Old Route 9 area from Old Hopewell Road through Middlebush / Myers Corners Road to U.S. Route 9, and the Hughsonville, Chelsea, New Hackensack, Swartoutville and Myers Corners Hamlets are existing centers of activity that can be enhanced and redesigned to promote community character in the Town.” Moreover, Objective B under Community Appearance and Character on Page 10 states, “Develop the Hughsonville, Chelsea, New Hackensack, Swartoutville and Myers Corners Hamlets, and the Old Route 9 District as vibrant, traditional town/village centers.” The proposed project is situated in the center of the Hughsonville Hamlet and will contribute additional residential density within a mixed use building featuring Hamlet-appropriate architecture, which is consistent with this objective.

In the Population and Housing section, the Plan states on Page 35 that, “While there are several non-residential zoning districts that permit residential use as principal or special permit uses (including the HB, MU, HM, NB, GB and SC Districts), there has been very little residential construction in these zones in the last 10 years. Possible deterrents are requirements for elevators and fire separation, additional water and sewer demands, floor area ratios and parking requirements.” Implementation strategy G (Page 37) encourages development in existing centers, “such as the Old Route 9/Main Street district and the Hughsonville Hamlet, the Town should consider requiring new development to include housing either on the floor(s) above a retail use, or in some other location on the site.” The proposed project includes a mixed use building with three apartments located above, which is consistent with this strategy. The Applicant proposes to extend Town water infrastructure from New Hamburg Road to Marlorville Road, with an easement dedicated to the Town.

The Plan notes that Hughsonville is not functioning as a Town center at this time due to a lack of sufficient passers-by and sufficient pedestrian amenities such as sidewalks and public places. (Page 51). The Plan includes a Hughsonville Concept Plan (Figure V-1) within the recommendations section of the Community Appearance and Character chapter, which depicts a modified Route 9D, with southern traffic traveling the existing roadway and northern traffic traversing via a new road that would be constructed over properties to the south of existing Route 9D. The Concept Plan also shows additional development and parking within the project site in addition to the buildings that currently occupy the site. To date, the Concept Plan has not been realized. Similar to the Concept Plan, the proposed project would bring new development to the project site. The proposed application includes the construction of a sidewalk along Route 9D and New Hamburg Road to help create a more walkable community which is essential to vibrant town/village centers. The addition of sidewalks and the establishment of an architecturally appropriate mixed use development will be a significant step towards achieving the goals and objectives of the Comprehensive Plan. No public parking is proposed, and it is anticipated that public parking projects are being undertaken by the Town in the area west of the intersection of NYS Route 9D and New Hamburg Road. Accordingly, the proposed project will not adversely affect the Concept Plan developed for the Hughsonville Hamlet as

it will include a new mixed residential and commercial use building featuring hamlet appropriate architectural design.

The Plan states within the Coordinating Water and Sewer Service with Land Use Planning on Page 74.

*The Community Character and Land Use Chapters call for developing and/or enhancing community centers in four main locations: the Old Route 9 District, the Hughsonville Hamlet, Chelsea Hamlet and Myers Corners. By directing development to these areas, the Town will better protect existing rural and semi-rural areas. But Wappinger's opportunities for creating higher density housing cannot be achieved without central water and sewer service. Currently, none of these four areas, except for the southern area of the old Route 9 commercial district, are served by central water or sewerage systems. Plans for allowing increased densities in these areas must be accompanied by plans to serve these areas with central utilities.*

The Applicant proposes to extend Town water infrastructure from New Hamburg Road to Marlorville Road, with an easement dedicated to the Town. The Applicant will construct a subsurface disposal system for the uses as there is no centralized sewer system in this area. The Town has indicated during previous Planning Board meetings, they do not anticipate municipal sewer in the vicinity of the project in the near future. Therefore, the proposed project to bring a mixed use residential and commercial building to Hughsonville with three residential apartments is consistent with this objective.

Under Land Use, the Hughsonville Hamlet is identified as needing special attention (Page 93) and the Plan states, "In Hughsonville, mixed residential and commercial uses and building renovations are needed, along with a plan for accommodating increasing traffic volumes through the hamlet."

The Applicant prepared a traffic impact study, which indicated that there would be no significant adverse impacts to traffic conditions. The project's traffic circulation design includes right in and right out only access off NYS Route 9D and full access off New Hamburg Road, with the exception of no left turns from the project site between the hours of 4 PM – 6PM. The access off NYS Route 9D is located approximately 185 FT from the intersection of NYS Route 9D and Hamburg Road. The development of the site allows for an ample 10-foot shoulder at the northeast corner of the NYS Route 9D and New Hamburg Road intersection and for a continuous sidewalk along the frontage on NYS Route 9D and New Hamburg Road.

Furthermore, the project includes several other traffic improvements, including new curbing along both NYS Route 9D and New Hamburg Road frontage. In addition, along the New Hamburg Road frontage, the pavement will be widened and full depth pavement will be installed across the entire frontage from Route 9D to the driveway. This additional pavement width will ease the traffic movement for traffic moving from Old Hopewell Road towards New Hamburg Road. New Hamburg Road will also be widened at its approach to Route 9D to increase to a two lane approach, including the provision of a separate left turn lane entering the proposed project's New Hamburg Road site driveway. Upgrades to the signal equipment will include a new communication modem, updated actuation and transfer switch. The updated actuation will include a camera and/or other equipment as specified by NYSDOT. These upgrades will improve the efficiency of the intersection operation and will provide full actuation for all movements. New pavement markings and signing will be implemented to guide traffic flow through the intersection.

The establishment of an architecturally appropriate mixed use development, large investment in pedestrian infrastructure, provision of capital upgrades to the Town’s water infrastructure, and improved traffic conditions will be a significant step towards achieving local Town goals and will be a significant win over the current condition of this site and pedestrian and vehicular conditions. As demonstrated, the proposed development of the site with a gasoline fueling station and convenience store with apartments above is consistent with the Comprehensive Plan.

### 2.1.3 Town of Wappinger Zoning

The project site is situated in the Hamlet Mixed Use (HM) zoning district, see Figure 4. The proposed development of the site includes a gasoline fueling station with a convenience store, and three one-bedroom apartments above, which is allowed by special permits pursuant to §240-52 and §240-81.7 of the Zoning Ordinance. The bulk table shown on the title sheet of the site plan indicates that the project is compliant with zoning, with one exception. A waiver per §240-21D<sup>2</sup> will be sought for the front yard setback off New Hamburg Road and NYS Route 9D.

With regard to parking, a retail use requires one space per 150 SF of first floor area. Therefore, the proposed 3,800 SF fueling station/convenience store requires 26 parking spaces. A multi-family dwelling requires one and a half spaces for each dwelling unit plus a ½ space for each bedroom. Therefore, the three one-bedroom apartments require six spaces. The site design proposes 32 parking spaces, including four spaces at the pumps, which meets the parking requirement.

The special use requirements of §240-52 Gasoline Filling Stations, are as follows:

A. Fuel pumps and storage tank inlets shall be set back at least 25 and 15 feet, respectively, from the perimeter property lines of the site. Further, fuel pumps and storage tank inlets shall be located and oriented in such a manner as to prevent the stacking of vehicles into any road right-of-way and the blocking of any point of site ingress or egress. For the purposes of this section, canopies over commercial fuel pumps and filling areas shall be permitted to extend into the minimum required front yard for the district in which the property is located, but in no case shall any canopy be located within five feet of any lot line.

The proposed project complies with these requirements.

B. All automobile parts, partially dismantled motor vehicles or similar articles shall be stored within a building. All repair and service work, including car washing, but excluding emergency service and the sale of fuel and lubricants, shall be conducted entirely within either a building or, where deemed appropriate by the Planning Board due to such factors as the size of the property involved and/or its location, shall be conducted entirely within a fenced-in area in which such work is visually screened from all adjoining properties and roadways. In no case shall any vehicles awaiting service or repair work be stored outdoors for a period exceeding five days, unless such

---

<sup>2</sup> Pursuant to Town Code § 240-81.7.C, a mixed-use development in the HM District must comply with the minimum front, side and rear yard requirements of the RMF-3 Multifamily Residence District. Since the Applicant is required to comply with the Town’s residential dimensional requirements, Section 240-21.D is applicable to this project.

vehicles are entirely located within a fenced-in area and are visually screened from all adjoining properties and roadways. Body work, major structural repair or painting shall not be permitted.

No repair and/or service work is proposed as part of the proposed action.

C. Use of a building for any residence or sleeping quarters shall not be permitted, except that in the Hamlet Mixed Use District, dwelling units which are separate from the gas station use may be permitted above the commercial ground floor use in the principal gas station building.

The proposed project complies with this requirement. The entry to the residential apartments will be on the west and south sides of the building.

As demonstrated, the proposed action complies with the requirements of §240-52.

The special use requirements of §240-81.7 Mixed Uses, are as follows:

A. Density.

(1) The residential density in a mixed-use development shall not exceed three dwelling units per acre of net lot area devoted to the residential component of the mixed use.

The proposed action includes three dwelling units on a 1.00 acre site, which complies with the requirement.

(2) The commercial density in a mixed-use development shall not exceed the maximum floor area ratio (FAR) for the zoning district in which the development is located, based upon the net lot area devoted to the commercial component of the mixed use.

The net lot area devoted to the commercial component (i.e. the retail store) of the mixed use is 0.74 acres. This area does not include the one-acre area devoted to the residential component of the mixed use and also does not include 0.05-acre area devoted to the fueling component of the proposed gasoline station.

The commercial density in the mixed use development does not exceed the maximum FAR for the HM District. The maximum FAR for the HM District is 0.5, the FAR of the commercial retail store is  $0.11$  ( $3,630$  SF (building footprint) /  $32,234.4$  SF (lot area devoted to commercial component) =  $0.11$ ).

(3) The residential and commercial components of the mixed use shall not, individually or in combination, exceed the maximum density standards of Subsection A(1) and (2) immediately above. Further, the net lot area used to derive density for the residential component of the mixed use shall not be utilized to derive density for the commercial component and vice versa.

The proposed action complies individually and in combination for residential and commercial based upon A(1) and A(2).

B. Minimum residential and commercial components. As measured by net lot area, the mixed use shall be at least 25% residential and at least 25% commercial.

The proportion of the property designated residential is equivalent to 1.00 ac (55.87%), which exceeds the 25% threshold of the site's total acreage (1.79 ac.). The proportion of the property designated to the commercial component is 0.74 ac (41.89%), which exceeds the 25% threshold of the site's total acreage (1.79 ac.). The proposed action includes a 3,630 SF convenience store with three dwelling units and associated residential use space comprising 3,630 SF on the second floor for an approximately 50/50 split, which complies with the requirement.

C. Yards. The mixed-use development shall comply with the minimum front, side and rear yard requirements of the RMF-3 Multifamily Residence District.

The bulk table shown on the title sheet of the site plan indicates that the project is compliant with zoning, with some exception.

An exception per §240-21D is being sought for the front yard setback off New Hamburg Road and NYS Route 9D because within 150 feet of the project site there is a pronounced uniformity of alignments of the depths of front yards less than the required minimum depths specified in the Schedule of Dimensional Regulations for Residential Districts. The proposed front yard conforms as nearly as practicable with those existing on adjacent lots located on the north side of NYS Route 9D, which on average have front yards of less than 10 feet. Similarly, the proposed building is aligned with the building located immediately north on New Hamburg Road, which is setback approximately 57.2 feet from the front property line. As indicated both NYS Route 9D and New Hamburg Road are developed with buildings that currently encroach on the required front yard setback. The proposed facility has been designed to be uniform with existing buildings to maintain a consistent street front within the Hamlet center.

Per §240-43(A)(1)(b), the proposed use will implement or otherwise not interfere with the statement of purposes found in §240-2 or the rationale/intent of the HM Zoning District per §240-7, as noted below.

§ 240-2 Statement of purposes.

For the purpose of promoting the health, safety, morals and the general welfare of the community, the Town Board of the Town of Wappinger, County of Dutchess and State of New York, under the authority granted by § 261 of the Town Law and in accordance with the procedures in § 264 of the Town Law and § 239-m of the General Municipal Law, hereby adopts this chapter in furtherance of the adopted Town law, including the following:

A. To guide the future development of the Town in accordance with a Comprehensive Plan designed to represent and promote the most beneficial and convenient relationship among the residential, commercial, industrial and public areas of the Town considering the suitability of each area for such uses as indicated by existing conditions, trends and development and changing modes in living, and have due regard for the use of land, building development and social, cultural

and economic activity, both within the Town and with respect to the relationship of the Town to area outside thereof.

Proposed Project: No zoning text amendment or zoning map amendment is proposed as part of the project. The proposed action incorporates two special permit uses on the site. Such uses are expressly permitted by the Zoning Code in the HM District.

B. To secure safety from fire, flood, panic and other dangers.

Proposed Project: The Applicant proposes to extend Town water infrastructure from New Hamburg Road to Marlerville Road, with an easement dedicated to the Town. Furthermore, the project includes several traffic improvements, including new curbing along both NYS Route 9D and New Hamburg Road frontage as well as full depth shoulder installation in this area. In addition, along the New Hamburg Road frontage, the pavement will be widened, and full depth pavement will be installed across the entire frontage from Route 9D to the driveway. This additional pavement width will ease the traffic movement for traffic moving from Old Hopewell Road towards New Hamburg Road. New Hamburg Road will also be widened at its approach to Route 9D to increase to a two lane approach, including the provision of a separate left turn lane entering the proposed project's New Hamburg Road site driveway. Upgrades to the signal equipment will include a new communication modem, updated actuation and transfer switch. The updated actuation will include a camera and/or other equipment as specified by NYSDOT. These upgrades will improve the efficiency of the intersection operation and will provide full actuation for all movements. New pavement markings and signing will be implemented to guide traffic flow through the intersection. These improvements will aid emergency operations and the project will be constructed and operated pursuant to applicable regulations to ensure safety.

C. To provide adequate light, air and privacy.

Proposed Project: The proposed project will not interfere with the Town's objective to provide adequate light, air and privacy.

D. To prevent overcrowding of the land and undue congestion of population.

Proposed Project: The proposed project includes a gasoline filling station, 3,630 square foot (SF) convenience store, and three one-bedroom apartments on the 1.79-acre (ac) site that is currently occupied by three residential homes, a multi-family residence, single apartment, a garage and a bar. The proposed development will occupy a prominent corner within the Hamlet and is designed to highlight the new residences at the street front to encourage the Hughsonville Hamlet aesthetic. The Proposed Action will serve residents, employees of nearby businesses and visitors in the area, providing needed goods and services to promote the growth of this community. The proposed project exceeds the Town's minimum lot area requirements and meets the Town's residential

density requirements for mixed use projects. The proposed development does not overcrowd the land or result in undue congestion.

E. To promote the most beneficial relation between the use of land and buildings and the circulation of traffic throughout the Town, having particular regard to the avoidance of congestion of streets and provision of safe and convenient vehicular and pedestrian traffic movements appropriate to the various uses of land and buildings throughout the Town.

Proposed Project: The proposed project incorporates local architectural styles (e.g., clapboard siding, cornices with brackets, asphalt roof shingles, double hung windows and stone, brick or concrete foundations) into the design. The project will bring a mixed use redevelopment project to the center of the Hughsonville Hamlet and will provide ample landscaping, new sidewalks along Route 9D and New Hamburg Road, and pedestrian-scale connections through the site. The proposed gasoline pumps and canopy will take a secondary position and the parking will be located in the rear interlaced with extensive landscaping. See also the response to B.

F. To facilitate the adequate provision of transportation, water, schools, parks and other public requirements.

Proposed Project: The proposed project will positively contribute to the Town's objective to provide transportation, water, schools, parks and other public requirements. As described above, the Applicant proposes to extend Town water infrastructure from New Hamburg Road to Marlorville Road, with an easement dedicated to the Town. In addition, the project includes several traffic improvements. See also the response to B.

G. To protect and conserve the value of land and buildings and the social and economic stability of all parts of the Town.

Proposed Project: No zoning text amendment or zoning map amendment is proposed as part of the project. The proposed action incorporates two special permit uses on the site. Such uses are expressly permitted by the Zoning Code in the HM District. The proposed project will result in economic growth for the community. The proposed business will be a positive addition to the community. In addition, the Applicant proposes to extend Town water infrastructure from New Hamburg Road to Marlorville Road, with an easement dedicated to the Town. The extension of water infrastructure will allow additional growth in the community and will increase the value of land and buildings. This will bring economic and social stability.

H. To prevent the pollution of watercourses and wetlands; to safeguard the water table; to avoid hazardous conditions and excessive damage resulting from stormwater runoff and flooding; and to encourage the appropriate use and sound management of natural resources throughout the Town.

Proposed Project: The proposed project will be located in a developed area of the Town and will not adversely impact watercourses or wetlands. The site's development will be

undertaken consistent with the NYSDEC general permit for stormwater discharges during construction and stormwater practices will be located on site. The site is not located within a 100-year floodplain and there are no watercourses or wetlands located on the property.

I. To preserve the natural beauty of the physiography of the Town, to protect the Town against unsightly, obtrusive and obnoxious land uses and operations to enhance the aesthetic aspect of the natural and man-made elements of the Town and to ensure appropriate development with regard to those elements.

Proposed Project: The HM District is zoned to include the Hughsonville Hamlet and the area generally located at the intersection of New Hamburg Road and NYS Route 9D. The proposed action incorporates two special permit uses on the site. Such uses are expressly permitted by the Zoning Code in the HM District. The intersection of these two main roadways is an obvious and suitable choice for a gas station. Notwithstanding that, the development also includes new residential apartments facing the intersection, which will enliven the district.

J. To promote the preservation of the existing historic character of the Town and to encourage the development of uses which would add to or be in harmony with this character.

Proposed Project: The building located at the corner of New Hamburg and NYS Route 9D, built in 1870, has undergone multiple modifications (1900, 1963, and 2000) and is clad in vinyl siding. The remaining buildings are deteriorating, and the proposed project incorporates local architectural styles (e.g., clapboard siding, cornices with brackets, asphalt roof shingles, double hung windows and stone, brick or concrete foundations) into the design. The development requires certain characteristics that make the reuse of the corner building structure infeasible.

K. To provide adequate and suitably located areas for recreation activities.

Proposed Project: The proposed project will not interfere with the Town's objective to provide adequate and suitable recreation areas.

L. To bring the gradual conformity of the uses of land and buildings throughout the Town to the adopted Town Development Plan and to minimize conflicts among the uses of land and buildings.

Proposed Project: The proposed project will result in a conforming use within the HM District.

#### §240-7 Rationale/intent of various district designations

HM - Hamlet Mixed Use. Intent: To preserve the historical character, concentrated development pattern and mixture of uses in existing commercial hamlets, particularly Hughsonville and Swartoutville, by encouraging restoration, reuse and visual improvement of existing structures.

Proposed Project: The Applicant is the owner of the corner lot (NYS Route 9D and New Hamburg Road), identified as tax lot 040637, which is currently occupied by a house that was built around the 1870s. The house was previously used as an apartment building. The current owner, the Applicant, purchased this property to increase the project site for utility needs (e.g., septic fields and stormwater practices). Currently, there is no water or sewer service in this area and the Applicant proposes to extend Town water infrastructure from New Hamburg Road to Marlorville Road, with an easement dedicated to the Town on the project properties. The Town will be responsible for securing an easement on parcel 6157-01-069663 (parcel between project site and Marlorville Road). The project site is located within the Hamlet Mixed Use (HM) zoning district and could be developed with several potential uses, including a bank, a restaurant, a theater, professional and medical offices (permitted with no special use permit), which could result in several noticeable changes similar to the proposed project. Given that the current property owners desire to sell, this corner of the hamlet is rife for redevelopment. Gas stations and convenience stores, like those uses listed above, require certain characteristics that make the reuse of the corner structure infeasible, including ample vehicular circulation space and proper distancing from underground gasoline tanks. Aside from the corner structure, the remaining buildings are deteriorating, and the proposed project incorporates local architectural styles (e.g., clapboard siding, cornices with brackets, asphalt roof shingles, double hung windows and stone, brick or concrete foundations) into the design. Furthermore, the project will bring a mixed use redevelopment project to the center of the Hughsonville Hamlet and will provide ample landscaping, new sidewalks along Route 9D and New Hamburg Road, and pedestrian-scale connections through the site. The proposed development will occupy a prominent corner within the Hamlet and is designed to highlight the new residences at the street front to encourage the Hughsonville Hamlet aesthetic. The proposed gasoline pumps and canopy will take a secondary position and the parking will be located in the rear interlaced with extensive landscaping.

As described above, the establishment of an architecturally appropriate mixed use development, large investment in pedestrian infrastructure, provision of capital upgrades to the Town's water infrastructure, and improved traffic conditions will be a significant step towards achieving local Town goals and will be a significant win over the current condition of this site and pedestrian and vehicular conditions.

Special Permitted Uses are also required to comply with the following standards listed in §240-44:

- A. The location and size of the use, the nature and intensity of the operations involved in or conducted in connection with it, the size of the site in relation to it and the location of the site with respect to streets giving access to it, are such that it will be in harmony with the appropriate and orderly development of the district in which it is located.

The proposed gasoline filling station with a convenience store and three, one-bedroom apartments above is permitted by special use permit pursuant to §240-52 and §240-81.7. The Comprehensive Plan indicates that additional residential density in the form of mixed use development is a desired use within the HM zoning district. The proposed project

would comply with applicable landscaping requirements and would replace existing buildings with an attractive mixed use development.

B. The location, nature and height of buildings, walls, fences and the nature and extent of existing or proposed plantings on the site are such that the use will not hinder or discourage the appropriate development and use of adjacent land and buildings.

The bulk table shown on the title sheet of the site plan indicates that the project is generally compliant with zoning, with a minor exception.

As discussed above an exception from §240-21D will be sought for the 75-foot minimum required front yard setback on NYS Route 9D and New Hamburg Road. This request is being made to ensure capability with local context and consistency with the Greenway Compact Program design guidance. The proposed front yard conforms as nearly as practicable with those existing on adjacent lots on NYS Route 9D, which on average have front yards of less than 10 feet. Similarly, the proposed building is aligned with the building located immediately north on New Hamburg Road, which is setback approximately 57.2 feet from the front property line. A review of historical maps and existing structures in the hamlet indicate that a 75 FT setback would be contrary to the goals of the Comprehensive Plan and the Greenway Compact Program which both encourage traditional neighborhood design. A 75 FT front setback would place the structure further from the roadway than the adjacent structures and create a suburban style development pattern, which is not desired.

C. Operations in connection with any special permit use will not be more objectionable to nearby properties by reason of noise, fumes, vibration, illumination or other characteristics, than would be the operations of any permitted use not requiring a special permit.

The proposed gasoline filling station with a convenience store and three, one-bedroom apartments above is permitted by special use permit pursuant to §240-52 and §240-81.7. The proposed project will include the installation of two, 12,000 gallon underground petroleum bulk storage tanks. The double walled fiberglass tanks will feature a monitoring space between the walls to allow for the containment of leaked product from the primary tank and continuous automatic leak detection functions (see Attachment E). The new tanks will require NYSDEC registration for underground bulk petroleum storage. As demonstrated, the proposed action complies with the requirements of §240-52 for gasoline filling stations and will meet applicable local, state and federal regulations. Specifically, Article 12, Title 10 of the Environmental Conservation Law, "Control of Bulk Storage of Petroleum," regulates how fuel is stored and dispensed. The NYSDEC has regularly updated these standards to ensure that the risk associated with handling petroleum is minimized. Facility registration with NYSDEC ensures compliance with these standards.

The Town of Wappingers General Legislation Chapter 166 “Noise” provides clear and enforceable limits on noise levels. The proposed project will, at a minimum, adhere to those standards to ensure that the surrounding properties are not unduly disturbed.

D. Parking areas will be of adequate size for the particular use, will be properly located and suitably screened from adjoining residential uses and the entrance and exit drives shall be laid out so as to achieve maximum safety.

The site includes landscaping and required parking pursuant to the Zoning Ordinance requirements. Recognizing that the project site is in a traditional Hamlet, the Applicant has sited the parking amongst ample landscaping and provides the minimum required surface parking.

#### **2.1.4 Dutchess County Greenway Compact Program**

In 2002, the Town became a participating community in the Dutchess County Greenway Compact Program. As such, the Town adopted as a statement of land use policies, principles and guides, the document entitled "Greenway Connections: Greenway Compact Program and Guides for Dutchess County Communities" dated March 8, 2000. The Greenway Compact promotes intermunicipal cooperation on five complementary goals:

- Natural and cultural resource protection;
- Economic development including agriculture, tourism, and urban redevelopment;
- Public access and trail systems, including a Hudson River Greenway Trail;
- Regional planning; and
- Heritage and environmental education.

The project site is located within a “Center” as described in the Centers: Compact, Complete, and Connected Guide. Centers are described in part as, “focal points for community history, commercial exchange, and close-knit development.” The Guide states, “In order to promote a stronger sense of community, encourage efficiencies in land use, energy, and transportation, and protect the rural countryside from commercial strip and residential sprawl development, most new growth should be concentrated in and around existing or emerging centers. This may include infill between buildings, redevelopment, or extensions of existing centers within walkable distances.”

The Greenway Compact describes Hughsonville, in part as, “a small historic hamlet that has become dominated by traffic due to a lack of sidewalks, heavy volumes on NYS Route 9D, and cars going to the nearby New Hamburg train station. The Town Plan included a Hughsonville Concept Plan to address these issues, but it has proved difficult to implement.”

The project will bring a mixed use redevelopment project to the center of the Hughsonville Hamlet and will provide ample landscaping, new sidewalks along Route 9D and New Hamburg Road, and pedestrian-

scale connections through the site. The site will be accessible via two accesses: 1) two-directional entry off New Hamburg; 2) right in/right out entry off NYS Route 9D (southbound lane). The proposed development will occupy a prominent corner within the Hamlet and is designed to highlight the new residences at the street front to encourage the Hughsonville Hamlet aesthetic. The proposed gasoline pumps and canopy will take a secondary position and the parking will be located amongst extensive landscaping. The proposed building incorporates local architectural styles (e.g., clapboard siding, cornices with brackets, asphalt roof shingles, double hung windows and stone, brick or concrete foundations) into the design. The Applicant proposes to extend Town water infrastructure from New Hamburg Road to Marlerville Road, with an easement dedicated to the Town.

Furthermore, the project includes several traffic improvements, including new curbing along both NYS Route 9D and New Hamburg Road frontage as well as full depth shoulder installation in this area. In addition, along the New Hamburg Road frontage, the pavement will be widened and full depth pavement will be installed across the entire frontage from Route 9D to the driveway. This additional pavement width will ease the traffic movement for traffic moving from Old Hopewell Road towards New Hamburg Road. New Hamburg Road will also be widened at its approach to Route 9D to increase to a two lane approach, including the provision of a separate left turn lane entering the proposed project's New Hamburg Road site driveway. Upgrades to the signal equipment will include a new communication modem, updated actuation and transfer switch. The updated actuation will include a camera and/or other equipment as specified by NYSDOT. These upgrades will improve the efficiency of the intersection operation and will provide full actuation for all movements. New pavement markings and signing will be implemented to guide traffic flow through the intersection.

The establishment of an architecturally appropriate mixed use development, large investment in pedestrian infrastructure, provision of capital upgrades to the Town's water infrastructure, and improved traffic conditions will be a significant step towards achieving the goals of the Greenway Compact and will be a significant win over the current condition of this site and pedestrian and vehicular conditions.

The Greenway Compact's Guidelines for Gas/Convenience Store Guide suggest the following:

- Highlight the store up front in a well-landscaped setting with the parking, pumps, and canopy in a secondary position toward the rear.
  - The proposed development features the store up front off New Hamburg Road, with the fuel pumps and canopy taking a secondary position.
- Reflect traditional architecture of the community and region in building and roof forms, window proportions, materials, colors and details.
  - The architecture found in the Hamlet of Hughsonville along the Route 9D corridor is comprised of one- and two-story wood frame residential and commercial structures, outbuildings, barns, and masonry structures. Many of the residential and commercial structures included in the area between Old Hopewell Road intersection to the north to and Dean Avenue intersection to the south are situated close to the highway and the associated barns and outbuildings are set back further from the street. Most of these

structures are clad in clapboard siding, cornices with brackets, asphalt roof shingles, double hung windows and stone, brick or concrete foundations. The outbuildings / barns are generally clad with board and batten siding. The façade colors are primarily white with a mix of light earth tone colors and the barns / and outbuildings with a traditional red. The proposed gasoline / convenience store has taken all of the materials listed above into consideration and incorporated a variety of them into the building's façade design.

- The proposed architecture features Town-appropriate design. Elevations will be provided in the future to the Town.
- Provide a direct sidewalk connection to the store entrance at the front or side of the building.
  - Sidewalks are proposed along Route 9D and New Hamburg Road, with direct access to the store and residences, as part of the proposed action.
- Design all four sides of the store with windows and other architectural features to avoid visible blank walls.
  - The proposed architecture features Town-appropriate design, which reflects architectural standards found within the community. Elevations have been provided to the Town.
- Connect the canopy with the primary store structure whenever possible, and coordinate the roof design and supports even if not attached.
  - The canopy will use similar architectural treatments to align it with the building's aesthetics.
- Use recessed, non-glare lighting under the canopy, pedestrian-scale lighting around the building, and medium height downlighting in the parking area.
  - The lighting complies with Town Code.
- Encourage a monument-style sign integrated into a planter or landscaping and/or a wall or hanging sign, not standard pole signs or canopy signs.
  - The signage will comply with Town Code. The Applicant will use recessed, non-glare lighting under the canopy, pedestrian-scale lighting around the building, and medium height downlighting in the parking area.

As demonstrated, the proposed development of the site with a fueling station and convenience store with apartments above is consistent with the Greenway Compact.

## 2.2 SOILS AND WATER RESOURCES

### 2.2.1 Soils

The following table provides the soil characteristics for each soil type expected to be found on the project site, according to available Geographic Information Systems (GIS) information (Figure 5) and the USDA Natural Resources Conservation Service website.

**Table 1: Soil Types on the Project Site**

% of SITE	SOIL SYMBOL	SOIL TYPE	SLOPES	DRAINAGE	DEPTH TO WATER TABLE (FT)	DEPTH TO BEDROCK (INCHES)
100	DwB	Dutchess-Cardigan complex, undulating, rocky	1 to 6%	well	>6	
		Dutchess (40%)		well	>6	>60
		Cardigan (30%)		well	>6	20 to 40

Therefore, the proposed development is not expected to encounter a high-water table during construction, and soils appear to be suitable for the installation of subsurface sewage disposal system (SSDS). Recent soil testing for the subsurface sewage disposal system (SSDS) did not reveal bedrock. Based on this information, the proposed redevelopment would not result in any significant adverse impacts related to soils.

### 2.2.2 Water Resources

According to GIS mapping (Figure 6) and the NYSDEC Environmental Resource Map (Figure 6), the project site does not contain any NYSDEC streams, wetlands or adjacent areas, or National Wetland Inventory (NWI) wetlands. The project site is not located over a US EPA designated Sole Source aquifer, nor is it located over unconsolidated aquifers in New York State as found in available 2011 GIS data available from the New York State GIS Clearinghouse. Therefore, no significant adverse impacts to water resources will result from the proposed project.

## 2.3 UTILITIES

### 2.3.1 Water and Wastewater

As discussed in Section 2.1, this part of the Hughsonville Hamlet is not currently served by municipal water or wastewater infrastructure. The Applicant proposes to extend Town water infrastructure from New Hamburg Road to Marlerville Road, with an easement dedicated to the Town. For wastewater, the Applicant will build an on-site septic disposal system for the convenience store and three, one-bedroom apartments. The Planning Board has informed the Applicant they do not anticipate municipal sewer in the area in the near future.

Based on the New York State Department of Environmental Conservation Water and Wastewater Systems Design and Construction Standards, the design flow for a facility with a public toilet is 400 gallons per day (gpd). The New York State Department of Environmental Conservation (NYSDEC) Design Standards for Intermediate Sized Wastewater Treatment Systems, March 2014 does not contain expected hydraulic loading rates for convenience store with minor food preparation. Therefore, our office has researched surrounding counties for theoretical sewage flows associated with this particular use. Enclosed is a copy of Table 1 – Project Density Loading Rates & Design Sewage Flow Rates from the Suffolk County Department of Health Services (Attachment A). This table provides a hydraulic load for a “Wet store w/ food (Deli/take-out with max 16 seats single service), where single service is defined as disposable plates, silverware & cups of 0.15 GPD for each gross square foot of floor space.” The proposed convenience store will not have seating. Based on this loading 570 GPD would be the expected flow. Applying a reduction for modern water fixtures reduces the design flow by 20% to 456 GPD.

According to the New York State Department of Environmental Conservation (NYSDEC) Design Standards for Intermediate Sized Wastewater Treatment Systems, March 2014, an apartment results in 110 gpd for bedroom for post-1994 plumbing code fixtures. Therefore, the three, one-bedroom apartments would demand/generate 330 gpd.

The proposed development of the site with a gasoline fueling station, convenience store and three (one-bedroom) apartments above is expected to result in 786 gpd water usage and wastewater generation.

The proposed development would require a connection to the municipal water supply, which requires review and approval by the Town of Wappinger and Dutchess County Department of Behavioral and Community Health (DCDBCH). A subsurface disposal system (SSDS) will be constructed for the project, which requires review and approval by the Dutchess County Department of Behavioral and Community Health (DCDBCH).

### **2.3.2 Stormwater**

The proposed development of the 1.79-acre site for a gasoline fueling station, convenience store, and three, one-bedroom apartments would result in demolition of nine buildings and related existing impervious infrastructure totaling 0.61 acres. The proposed project will result in an approximately 0.19-acre increase for a total of approximately 0.80 acres of impervious surface. The design plans and a Stormwater Pollution Prevention Plan will be prepared in conformance with the New York State Stormwater Management Design Manual, dated January 2015 and New York State Standards and Specifications for Erosion and Sediment Control, dated August 2005.

Currently runoff flows off site on to NYS Route 9D towards two catch basins within the right-of-way (ROW). Proposed design will eliminate sheet flow onto NYS Route 9D and establish direct connections to the two existing catch basins in the ROW. On-site stormwater management consists of a variety of best management practices. Roof runoff from the canopy, building, and some parking areas is collected and routed through a hydrodynamic separator (providing water quality pre-treatment) and then through infiltrator chambers. Remaining run off from the fueling area and remaining parking will be pretreated (hydrodynamic separator) and then released through subsurface piping to a lined bioretention area. A

yard drain will collect any overflow during storm events. Therefore, the proposed project is not expected to result in any adverse impacts in regard to stormwater.

### **2.3.3 Solid Waste**

According to the Development Impact Assessment Handbook, Urban Land Institute, 1994, a residential use is expected to generate 0.00175± tons per resident per day and a retail use would generate 0.001± tons of solid waste per retail employee per day. According to the Rutgers University Center for Urban Policy Research, Residential Demographic Multipliers, Estimates of the Occupants of New Housing, Table 1, the total household size for a residential facility with two to four units is 2.20 persons per one-bedroom unit, which results in approximately 6.6 residents for the three proposed one-bedroom apartments. Thus, the apartments would be expected to generate 0.0115 tons of solid waste per day. The gasoline station/convenience store with three employees (0.001± tons per office employee per day) would be expected to generate 0.003 tons of solid waste per day, for a total of 0.0146 tons of solid waste per day or 0.445 tons per month.

## **2.4 TRAFFIC AND PARKING**

The project proposes four gas pumps (eight fueling stations), three residential apartments and a convenience market (3,630 SF). The revised Trip Generation Table is shown below. Since the revised development is generating similar traffic, the Traffic Impact Study (last revised February 11, 2021) analysis and conclusions are still applicable. A copy of the Traffic Impact Study and related documentation has been submitted separately.

**HOURLY TRIP GENERATION RATES (HTGR) AND ANTICIPATED  
 SITE GENERATED TRAFFIC VOLUMES**

**REVISED DEVELOPMENT PLAN**

GASLAND NYS ROUTE 9D TOWN OF WAPPINGERS, NY	ENTRY			EXIT		
	HTGR*	VOLUME	NEW TRIPS	HTGR*	VOLUME	NEW TRIPS
CONVENIENCE MARKET with GASOLINE PUMPS (8 FUELING POSITIONS)						
PEAK AM HOUR	10.38	83	50	10.38	83	50
PEAK PM HOUR	12.13	97	58	12.13	97	58
APARTMENT (4 DWELLING UNITS)						
PEAK AM HOUR	0.25	1	1	0.50	2	2
PEAK PM HOUR	0.50	2	2	0.50	2	2
TOTAL		VOLUME			VOLUME	
PEAK AM HOUR	-	-	51	-	-	52
PEAK PM HOUR	-	-	60	-	-	60

NOTES:

1) \* HTGR-HOURLY TRIP GENERATION RATES EXPRESSED IN TERMS OF TRIPS PER FUELING POSITION FOR LAND USE - 853 CONVENIENCE MARKET WITH GASOLINE PUMPS, AND PER DWELLING UNIT FOR LAND USE 220 - MULTIFAMILY HOUSING BASED ON THE INSTITUTE OF TRANSPORTATION ENGINEERS (ITE) PUBLICATION ENTITLED "TRIP GENERATION", 10TH EDITION, 2017.

2) NEW TRIPS INCLUDE A PASS-BY CREDIT OF 40% FOR GAS / CONVENIENCE USE.  
 IT SHOULD BE NOTED THAT THIS IS CONSERVATIVE SINCE DATA PUBLISHED BY ITE INDICATES THAT FOR THIS TYPE OF FACILITY, THE MAJORITY OF TRIPS (TYPICALLY IN EXCESS OF 75% OR MORE ARE ATTRACTED AS "PASS-BY OR DIVERTED LINK TRIPS" AND ARE NOT NEW TO THE SYSTEM

## 2.5 ENDANGERED, THREATENED AND RARE SPECIES AND SIGNIFICANT HABITAT

The NYSDEC Environmental Resource Map (Figure 7) indicates that there are known occurrences of endangered, threatened, or rare (ETR) species in the vicinity of the project site, and the EAF Mapper indicates the potential for the Indiana Bat (State and Federally endangered) and Bald Eagle (State threatened). An information request was submitted to the NYSDEC for further information and in a letter dated February 5, 2020 they indicated that the site is located within or near records of the Bald Eagle (threatened) and Indiana Bat (endangered). The letter states with regard to Bald Eagles, “based on the location of the project relative to the nearest documented bald eagle nest, the Department has determined that this project is not likely to impact this species. No further review is necessary for this species at this time.” With regard to avoiding impacts to Indiana Bat the letter states, “all tree removal must take place from October 1st through March 31st.” See Attachment C for more information.

The USFWS Official Species List (Attachment B) indicates the potential for the following species in the vicinity of the project site: Indiana Bat (endangered) and Northern Long-Eared Bat (threatened).

The proposed project would result in 1.79 acres of disturbance within the 1.79 acre site and will include the removal of approximately 26 trees. Clearing on the site would be restricted per NYSDEC to avoid impacts to bats.

## 2.6 HISTORIC AND ARCHEOLOGICAL RESOURCES

According to the NYS Office of Parks, Recreation, and Historic Preservation (NYSOPRHP) Cultural Resource Information System (CRIS) mapping (Figure 8), there are no listed or eligible for listing on the National or State Historic Register sites on or adjacent to the project area. The site is located within a known archeologically sensitive area. In an April 14, 2020 letter, NYSOPRHP stated, “it is the opinion of OPRHP that no properties, including archaeological and/or historic resources, listed in or eligible for the New York State and National Registers of Historic Places will be impacted by this project.” See Attachment D for more information. An updated project description was provided to NYSOPRHP to describe the addition of the corner parcel. In a March 9, 2021, NYSOPRHP stated, “Based upon this review, it is the opinion of OPRHP that no properties, including archaeological and/or historic resources, listed in or eligible for the New York State and National Registers of Historic Places will be impacted by this project.”

Furthermore, the proposed building architecture complies with the architectural and landscaping standards set forth in Town Code Section 240.35.D, as follows:

New structures should be constructed to a height visually compatible with the buildings and environment to which they are visually related.

Proposed Project: The proposed building is two stories in height and is compatible in height with other two-story structures in the hamlet.

The gross volume of any new structure should be visually compatible with the buildings and environment to which it is visually related.

Proposed Project: The volume and footprint are compatible with the existing structures in the hamlet.

In the elevations of a building, the proportion between the width and height in the facades should be visually compatible with the buildings and environment to which they are visually related.

Proposed Project: The proposed building proportions are consistent with the width and height of neighboring structures in the hamlet.

The proportions and relationships between doors and windows in the facades should be visually compatible with the buildings and environment to which they are visually related.

Proposed Project: The proposed building window and door proportions are comparable to the proportions of those found on both New Hamburg Road and Route 9D.

The rhythm of solids to voids, created by openings in the facade, should be visually compatible with the buildings and environment to which it is visually related.

Proposed Project: The proposed building windows and doors replicate the rhythm of solids and voids of those found on both New Hamburg Road and Route 9D.

The existing rhythm created by existing building masses and spaces between them should be preserved, insofar as practicable.

Proposed Project: The proposed building massing is similar to the two-story structures nearby.

The materials used in the facades should be visually compatible with the buildings and environment to which they are visually related.

Proposed Project: The proposed building materials: clapboard siding, asphalt roof shingles, double-hung windows, covered entrances have all been inherited from the local structures in the hamlet.

The texture inherent in the facades should be visually compatible with the buildings and environment to which they are visually related.

Proposed Project: The proposed building material textures: clapboard siding, asphalt roof shingles, double-hung windows, covered entrances have all been inherited from the local structures in the hamlet.

Colors and patterns used on the facades should be visually compatible with the buildings and environment to which they are visually related.

Proposed Project: A review of the hamlet colors and patterns were found to follow a white and neutral color palette. Four neutral colors were provided for review and the selection of a Navajo Beige was found to be an acceptable choice.

The design of the roof should be visually compatible with the buildings and environment to which it is visually related.

Proposed Project: The proposed structure was shown with a hip roof matching a few structures in the hamlet. A gable roof option and dormer option will also be provided for review.

The landscape plan should be sensitive to the individual building and to its occupants and their needs. Further, the landscape treatment should be visually compatible with the buildings and environment to which it is visually related.

Proposed Project: The proposed landscape plan includes a mix of plants and hardscapes, which have their own visual details, from various forms and shapes to an array of colors and textures. They complement and contrast each other, creating a cohesive and captivating landscape.

All facades should blend with other buildings via directional expression. When adjacent buildings have a dominant horizontal or vertical expression, this expression should be carried over and reflected.

Proposed Project: The proposed building blends vertically and horizontally with the other buildings in the hamlet.

Architectural details should be incorporated as necessary to relate the new with the old and to preserve and enhance the inherent characteristics of the area.

Proposed Project: A review of the hamlet façade details and fenestrations were adapted to the proposed building through the use of decorative brackets, braces and columns on the porches and cornices.

The setback of the buildings from the street or property line and the other yard setbacks should be visually compatible with the buildings and environment to which they are visually related.

Proposed Project: The proposed building is set back from the street similar to the commercial buildings in the surrounding area.

Signs should be of a size, scale, style, materials and illumination that are visually compatible with the building to which they relate and should further be visually compatible with the buildings and environment to which they are visually related.

Proposed Project: The building signage is compatible with the architecture of the building and includes landscaping at its base.

Based on the reasons presented above, no significant adverse impacts to historic or archaeological resources will occur as a result of the proposed project.



**FULL ENVIRONMENTAL ASSESSMENT FORM (FEAF)**  
**PART 1 FORM**

---



**Full Environmental Assessment Form**  
**Part 1 - Project and Setting**

**Instructions for Completing Part 1**

**Part 1 is to be completed by the applicant or project sponsor.** Responses become part of the application for approval or funding, are subject to public review, and may be subject to further verification.

Complete Part 1 based on information currently available. If additional research or investigation would be needed to fully respond to any item, please answer as thoroughly as possible based on current information; indicate whether missing information does not exist, or is not reasonably available to the sponsor; and, when possible, generally describe work or studies which would be necessary to update or fully develop that information.

Applicants/sponsors must complete all items in Sections A & B. In Sections C, D & E, most items contain an initial question that must be answered either “Yes” or “No”. If the answer to the initial question is “Yes”, complete the sub-questions that follow. If the answer to the initial question is “No”, proceed to the next question. Section F allows the project sponsor to identify and attach any additional information. Section G requires the name and signature of the applicant or project sponsor to verify that the information contained in Part 1 is accurate and complete.

**A. Project and Applicant/Sponsor Information.**

Name of Action or Project: Gas Land Petroleum - Route 9D		
Project Location (describe, and attach a general location map): 2361 Route 9D, Town of Wappinger, Dutchess County, NY		
Brief Description of Proposed Action (include purpose or need): The Applicant, Gas Land Petroleum, Inc., proposes to develop a gasoline filling station (four pumps with eight fueling stations), a 3,630 square foot (SF) convenience store and three, one-bedroom apartments located above with 32 parking spaces (including four parking spaces at the fueling stations) on a 1.79-acre (ac) site located at 123 – 125 New Hamburg Road and 2357 and 2361 – 2365 NYS Route 9D in the Town of Wappinger. The proposed project is located within the Hamlet Mixed Use (HM) Zoning District and the action requires a site plan approval from the Planning Board and two special permits for the gasoline filling station (pursuant to §240-81.7) and for permission to use the building as a mixed use (pursuant to §240-52). The property is comprised of four tax parcels, including: 135689-6157-01-048643 (0.21 ac), 135689-6157-01-057642 (0.20 ac), 135689-6157-01-057654 (0.69 ac), and 135689-6157-01-059643 (0.14 ac) owned by Charles Conklin and 135689-6157-01-040637-0000 (0.55 ac) owned by Gas Land Petroleum, Inc. The property is currently occupied by three residential homes, a multi-family residence, a garage and a bar comprising approximately 10,945 SF total. As part of the proposed action, these buildings would be demolished and the lot would be consolidated to form one tax parcel, which requires a subdivision approval from the Planning Board. The Applicant proposes to extend Town water infrastructure from New Hamburg Road to Marlerville Road to serve site.		
Name of Applicant/Sponsor: Gas Land Petroleum, Inc. (Zeidan Nesheiwat)	Telephone: 845-331-7545	E-Mail: gasland.zeidan@gmail.com
Address: 3 Ohioville Road		
City/PO: New Paltz	State: NY	Zip Code: 12561
Project Contact (if not same as sponsor; give name and title/role):	Telephone:	E-Mail:
Address:		
City/PO:	State:	Zip Code:
Property Owner (if not same as sponsor): Charles L. Conklin	Telephone:	E-Mail:
Address: P.O. Box 237		
City/PO: Hughsonville	State: NY	Zip Code: 12537

**B. Government Approvals**

**B. Government Approvals, Funding, or Sponsorship.** (“Funding” includes grants, loans, tax relief, and any other forms of financial assistance.)

Government Entity	If Yes: Identify Agency and Approval(s) Required	Application Date (Actual or projected)
a. City Counsel, Town Board, or Village Board of Trustees <input checked="" type="checkbox"/> Yes <input type="checkbox"/> No	Town Board approval - United Wappinger Water District connection	Spring 2021
b. City, Town or Village Planning Board or Commission <input checked="" type="checkbox"/> Yes <input type="checkbox"/> No	Site Plan; Lot Consolidation, Special Use Permit, MS4	Winter 2020
c. City, Town or Village Zoning Board of Appeals <input type="checkbox"/> Yes <input checked="" type="checkbox"/> No		
d. Other local agencies <input type="checkbox"/> Yes <input checked="" type="checkbox"/> No		
e. County agencies <input checked="" type="checkbox"/> Yes <input type="checkbox"/> No	DCDBCH for SSDS and Water; DC Planning GML 239m referral; DC highway work permit	Spring 2021 DC DCDBCH; Winter 2021 DC HWP; Fall 2020 DC Planning
f. Regional agencies <input type="checkbox"/> Yes <input checked="" type="checkbox"/> No		
g. State agencies <input checked="" type="checkbox"/> Yes <input type="checkbox"/> No	NYS DOT Highway Work Permit; NYSDEC GP-0-20-001	Fall 2020
h. Federal agencies <input type="checkbox"/> Yes <input checked="" type="checkbox"/> No		
i. Coastal Resources. i. Is the project site within a Coastal Area, or the waterfront area of a Designated Inland Waterway? <input checked="" type="checkbox"/> Yes <input type="checkbox"/> No  ii. Is the project site located in a community with an approved Local Waterfront Revitalization Program? <input type="checkbox"/> Yes <input checked="" type="checkbox"/> No iii. Is the project site within a Coastal Erosion Hazard Area? <input type="checkbox"/> Yes <input checked="" type="checkbox"/> No		

**C. Planning and Zoning** Project site is located within the State's Coastal Zone area. The Town of Wappinger does not have a local waterfront revitalization program (LWRP); therefore no coastal zone consistency determination by the Town is required.

**C.1. Planning and zoning actions.**

Will administrative or legislative adoption, or amendment of a plan, local law, ordinance, rule or regulation be the only approval(s) which must be granted to enable the proposed action to proceed?  Yes  No

- If Yes, complete sections C, F and G.
- If No, proceed to question C.2 and complete all remaining sections and questions in Part 1

**C.2. Adopted land use plans.**

a. Do any municipally- adopted (city, town, village or county) comprehensive land use plan(s) include the site where the proposed action would be located?  Yes  No  
 If Yes, does the comprehensive plan include specific recommendations for the site where the proposed action would be located?  Yes  No

b. Is the site of the proposed action within any local or regional special planning district (for example: Greenway; Brownfield Opportunity Area (BOA); designated State or Federal heritage area; watershed management plan; or other?)  Yes  No  
 If Yes, identify the plan(s):  
 Hudson River Valley National Heritage Area; Wappinger Creek Watershed Management Plan; Dutchess County Greenway Compact Program

c. Is the proposed action located wholly or partially within an area listed in an adopted municipal open space plan, or an adopted municipal farmland protection plan?  Yes  No  
 If Yes, identify the plan(s):

**C.3. Zoning**

- a. Is the site of the proposed action located in a municipality with an adopted zoning law or ordinance.  Yes  No  
If Yes, what is the zoning classification(s) including any applicable overlay district?  
Hamlet Mixed Use District (HM)
- b. Is the use permitted or allowed by a special or conditional use permit?  Yes  No
- c. Is a zoning change requested as part of the proposed action?  Yes  No  
If Yes,  
i. What is the proposed new zoning for the site? \_\_\_\_\_

**C.4. Existing community services.**

- a. In what school district is the project site located? Wappinger Falls Central School District
- b. What police or other public protection forces serve the project site?  
Dutchess County Sheriff
- c. Which fire protection and emergency medical services serve the project site?  
Hughsonville Fire District and EMStar Ambulance Service
- d. What parks serve the project site?  
Reese Park

**D. Project Details**

**D.1. Proposed and Potential Development**

- a. What is the general nature of the proposed action (e.g., residential, industrial, commercial, recreational; if mixed, include all components)? Mixed Residential (3, 1-bedroom apartments) and Commercial (Gas Station, Convenience Store)
- b. a. Total acreage of the site of the proposed action? \_\_\_\_\_ 1.79 acres  
b. Total acreage to be physically disturbed? \_\_\_\_\_ 1.79 acres  
c. Total acreage (project site and any contiguous properties) owned or controlled by the applicant or project sponsor? \_\_\_\_\_ 1.79 acres
- c. Is the proposed action an expansion of an existing project or use?  Yes  No  
i. If Yes, what is the approximate percentage of the proposed expansion and identify the units (e.g., acres, miles, housing units, square feet)? % \_\_\_\_\_ Units: \_\_\_\_\_
- d. Is the proposed action a subdivision, or does it include a subdivision?  Yes  No  
If Yes,  
i. Purpose or type of subdivision? (e.g., residential, industrial, commercial; if mixed, specify types)  
Commercial - lot consolidation of five parcels  
ii. Is a cluster/conservation layout proposed?  Yes  No  
iii. Number of lots proposed? 1  
iv. Minimum and maximum proposed lot sizes? Minimum 1.79 Maximum 1.79 Lot consolidation only
- e. Will the proposed action be constructed in multiple phases?  Yes  No  
i. If No, anticipated period of construction: \_\_\_\_\_ 12 months  
ii. If Yes:  
  - Total number of phases anticipated \_\_\_\_\_
  - Anticipated commencement date of phase 1 (including demolition) \_\_\_\_\_ month \_\_\_\_\_ year
  - Anticipated completion date of final phase \_\_\_\_\_ month \_\_\_\_\_ year
  - Generally describe connections or relationships among phases, including any contingencies where progress of one phase may determine timing or duration of future phases: \_\_\_\_\_  
\_\_\_\_\_  
\_\_\_\_\_

f. Does the project include new residential uses?  Yes  No  
 If Yes, show numbers of units proposed.

	<u>One Family</u>	<u>Two Family</u>	<u>Three Family</u>	<u>Multiple Family (four or more)</u>
Initial Phase	_____	_____	_____	3, 1-bed apt _____
At completion of all phases	_____	_____	_____	3 1-bed apt _____

g. Does the proposed action include new non-residential construction (including expansions)?  Yes  No  
 If Yes,

i. Total number of structures \_\_\_\_\_ 2 Building and Gasoline Fueling Station Canopy  
 ii. Dimensions (in feet) of largest proposed structure: \_\_\_\_\_ <35 height; \_\_\_\_\_ 82.5 width; and \_\_\_\_\_ 44 length  
 iii. Approximate extent of building space to be heated or cooled: \_\_\_\_\_ 7,260 square feet

h. Does the proposed action include construction or other activities that will result in the impoundment of any liquids, such as creation of a water supply, reservoir, pond, lake, waste lagoon or other storage?  Yes  No  
 If Yes,

i. Purpose of the impoundment: \_\_\_\_\_  
 ii. If a water impoundment, the principal source of the water:  Ground water  Surface water streams  Other specify: \_\_\_\_\_  
 iii. If other than water, identify the type of impounded/contained liquids and their source. \_\_\_\_\_  
 iv. Approximate size of the proposed impoundment. Volume: \_\_\_\_\_ million gallons; surface area: \_\_\_\_\_ acres  
 v. Dimensions of the proposed dam or impounding structure: \_\_\_\_\_ height; \_\_\_\_\_ length  
 vi. Construction method/materials for the proposed dam or impounding structure (e.g., earth fill, rock, wood, concrete): \_\_\_\_\_

**D.2. Project Operations**

a. Does the proposed action include any excavation, mining, or dredging, during construction, operations, or both?  Yes  No  
 (Not including general site preparation, grading or installation of utilities or foundations where all excavated materials will remain onsite)  
 If Yes:

i. What is the purpose of the excavation or dredging? \_\_\_\_\_  
 ii. How much material (including rock, earth, sediments, etc.) is proposed to be removed from the site?  
 • Volume (specify tons or cubic yards): \_\_\_\_\_  
 • Over what duration of time? \_\_\_\_\_  
 iii. Describe nature and characteristics of materials to be excavated or dredged, and plans to use, manage or dispose of them.  
 \_\_\_\_\_  
 \_\_\_\_\_  
 iv. Will there be onsite dewatering or processing of excavated materials?  Yes  No  
 If yes, describe. \_\_\_\_\_  
 \_\_\_\_\_  
 v. What is the total area to be dredged or excavated? \_\_\_\_\_ acres  
 vi. What is the maximum area to be worked at any one time? \_\_\_\_\_ acres  
 vii. What would be the maximum depth of excavation or dredging? \_\_\_\_\_ feet  
 viii. Will the excavation require blasting?  Yes  No  
 ix. Summarize site reclamation goals and plan: \_\_\_\_\_  
 \_\_\_\_\_  
 \_\_\_\_\_

b. Would the proposed action cause or result in alteration of, increase or decrease in size of, or encroachment into any existing wetland, waterbody, shoreline, beach or adjacent area?  Yes  No  
 If Yes:

i. Identify the wetland or waterbody which would be affected (by name, water index number, wetland map number or geographic description): \_\_\_\_\_  
 \_\_\_\_\_

ii. Describe how the proposed action would affect that waterbody or wetland, e.g. excavation, fill, placement of structures, or alteration of channels, banks and shorelines. Indicate extent of activities, alterations and additions in square feet or acres:

\_\_\_\_\_  
\_\_\_\_\_  
\_\_\_\_\_

iii. Will the proposed action cause or result in disturbance to bottom sediments?  Yes  No

If Yes, describe: \_\_\_\_\_

iv. Will the proposed action cause or result in the destruction or removal of aquatic vegetation?  Yes  No

If Yes:

- acres of aquatic vegetation proposed to be removed: \_\_\_\_\_
- expected acreage of aquatic vegetation remaining after project completion: \_\_\_\_\_
- purpose of proposed removal (e.g. beach clearing, invasive species control, boat access): \_\_\_\_\_
- proposed method of plant removal: \_\_\_\_\_
- if chemical/herbicide treatment will be used, specify product(s): \_\_\_\_\_

v. Describe any proposed reclamation/mitigation following disturbance: \_\_\_\_\_

c. Will the proposed action use, or create a new demand for water?  Yes  No

If Yes:

i. Total anticipated water usage/demand per day: \_\_\_\_\_ 786 gallons/day

ii. Will the proposed action obtain water from an existing public water supply?  Yes  No

If Yes:

- Name of district or service area: United Wappinger Water District
- Does the existing public water supply have capacity to serve the proposal?  Yes  No
- Is the project site in the existing district?  Yes  No
- Is expansion of the district needed?  Yes  No
- Do existing lines serve the project site?  Yes  No

iii. Will line extension within an existing district be necessary to supply the project?  Yes  No

If Yes:

- Describe extensions or capacity expansions proposed to serve this project: \_\_\_\_\_  
Service line extension from New Hamburg Road to Marlerville Road.
- Source(s) of supply for the district: \_\_\_\_\_

iv. Is a new water supply district or service area proposed to be formed to serve the project site?  Yes  No

If Yes:

- Applicant/sponsor for new district: \_\_\_\_\_
- Date application submitted or anticipated: \_\_\_\_\_
- Proposed source(s) of supply for new district: \_\_\_\_\_

v. If a public water supply will not be used, describe plans to provide water supply for the project: \_\_\_\_\_

vi. If water supply will be from wells (public or private), what is the maximum pumping capacity: \_\_\_\_\_ gallons/minute.

d. Will the proposed action generate liquid wastes?  Yes  No

If Yes:

i. Total anticipated liquid waste generation per day: \_\_\_\_\_ 786 gallons/day

ii. Nature of liquid wastes to be generated (e.g., sanitary wastewater, industrial; if combination, describe all components and approximate volumes or proportions of each): \_\_\_\_\_

Sanitary wastewater

iii. Will the proposed action use any existing public wastewater treatment facilities?  Yes  No

If Yes:

- Name of wastewater treatment plant to be used: \_\_\_\_\_
- Name of district: \_\_\_\_\_
- Does the existing wastewater treatment plant have capacity to serve the project?  Yes  No
- Is the project site in the existing district?  Yes  No
- Is expansion of the district needed?  Yes  No

• Do existing sewer lines serve the project site?  Yes  No  
 • Will a line extension within an existing district be necessary to serve the project?  Yes  No  
 If Yes:  
 • Describe extensions or capacity expansions proposed to serve this project: \_\_\_\_\_  
 \_\_\_\_\_  
 \_\_\_\_\_

iv. Will a new wastewater (sewage) treatment district be formed to serve the project site?  Yes  No  
 If Yes:  
 • Applicant/sponsor for new district: \_\_\_\_\_  
 • Date application submitted or anticipated: \_\_\_\_\_  
 • What is the receiving water for the wastewater discharge? \_\_\_\_\_

v. If public facilities will not be used, describe plans to provide wastewater treatment for the project, including specifying proposed receiving water (name and classification if surface discharge or describe subsurface disposal plans):  
New subsurface sewage disposal system  
 \_\_\_\_\_  
 \_\_\_\_\_

vi. Describe any plans or designs to capture, recycle or reuse liquid waste: \_\_\_\_\_  
None  
 \_\_\_\_\_

---

e. Will the proposed action disturb more than one acre and create stormwater runoff, either from new point sources (i.e. ditches, pipes, swales, curbs, gutters or other concentrated flows of stormwater) or non-point source (i.e. sheet flow) during construction or post construction?  Yes  No  
 If Yes:  
 i. How much impervious surface will the project create in relation to total size of project parcel?  
 \_\_\_\_\_ Square feet or 0.80 acres (impervious surface)  
 \_\_\_\_\_ Square feet or 1.79 acres (parcel size)

ii. Describe types of new point sources. Current runoff flows off site on to Route 9D towards two catch basins within the ROW. Proposed design will reduce sheet flow onto Route 9D and establish direct connection to one existing catch basins in ROW.  
 \_\_\_\_\_

iii. Where will the stormwater runoff be directed (i.e. on-site stormwater management facility/structures, adjacent properties, groundwater, on-site surface water or off-site surface waters)?  
See Note 2 below.  
 \_\_\_\_\_  
 \_\_\_\_\_

• If to surface waters, identify receiving water bodies or wetlands: \_\_\_\_\_  
N/A  
 \_\_\_\_\_

• Will stormwater runoff flow to adjacent properties?  Yes  No

iv. Does the proposed plan minimize impervious surfaces, use pervious materials or collect and re-use stormwater?  Yes  No

---

f. Does the proposed action include, or will it use on-site, one or more sources of air emissions, including fuel combustion, waste incineration, or other processes or operations?  Yes  No  
 If Yes, identify:  
 i. Mobile sources during project operations (e.g., heavy equipment, fleet or delivery vehicles)  
None  
 \_\_\_\_\_

ii. Stationary sources during construction (e.g., power generation, structural heating, batch plant, crushers)  
Temporary impacts during construction.  
 \_\_\_\_\_

iii. Stationary sources during operations (e.g., process emissions, large boilers, electric generation)  
Natural gas boiler, electric generation.  
 \_\_\_\_\_

---

g. Will any air emission sources named in D.2.f (above), require a NY State Air Registration, Air Facility Permit, or Federal Clean Air Act Title IV or Title V Permit?  Yes  No  
 If Yes:  
 i. Is the project site located in an Air quality non-attainment area? (Area routinely or periodically fails to meet ambient air quality standards for all or some parts of the year)  Yes  No  
 ii. In addition to emissions as calculated in the application, the project will generate:

- \_\_\_\_\_ Tons/year (short tons) of Carbon Dioxide (CO<sub>2</sub>)
- \_\_\_\_\_ Tons/year (short tons) of Nitrous Oxide (N<sub>2</sub>O)
- \_\_\_\_\_ Tons/year (short tons) of Perfluorocarbons (PFCs)
- \_\_\_\_\_ Tons/year (short tons) of Sulfur Hexafluoride (SF<sub>6</sub>)
- \_\_\_\_\_ Tons/year (short tons) of Carbon Dioxide equivalent of Hydroflouorocarbons (HFCs)
- \_\_\_\_\_ Tons/year (short tons) of Hazardous Air Pollutants (HAPs)

Note 2: On-site stormwater management consists of a variety of best management practices. Roof runoff from the canopy, building, and some parking areas is collected and routed through a hydrodynamic separator (providing water quality pre-treatment) and then through infiltrator chambers. Remaining run off from the fueling area and remaining parking will be pretreated (hydrodynamic separator) and then released through subsurface piping to a lined bioretention area. A yard drain will collect any overflow during storm events.

h. Will the proposed action generate or emit methane (including, but not limited to, sewage treatment plants, landfills, composting facilities)?  Yes  No

If Yes:

i. Estimate methane generation in tons/year (metric): \_\_\_\_\_

ii. Describe any methane capture, control or elimination measures included in project design (e.g., combustion to generate heat or electricity, flaring): \_\_\_\_\_

---

i. Will the proposed action result in the release of air pollutants from open-air operations or processes, such as quarry or landfill operations?  Yes  No

If Yes: Describe operations and nature of emissions (e.g., diesel exhaust, rock particulates/dust): \_\_\_\_\_

---

j. Will the proposed action result in a substantial increase in traffic above present levels or generate substantial new demand for transportation facilities or services? A traffic impact study is being provided to the Town separately.  Yes  No

If Yes:

i. When is the peak traffic expected (Check all that apply):  Morning  Evening  Weekend  
 Randomly between hours of \_\_\_\_\_ to \_\_\_\_\_.

ii. For commercial activities only, projected number of truck trips/day and type (e.g., semi trailers and dump trucks): \_\_\_\_\_

iii. Parking spaces: Existing 10 Proposed 32 Net increase/decrease +22

iv. Does the proposed action include any shared use parking?  Yes  No

v. If the proposed action includes any modification of existing roads, creation of new roads or change in existing access, describe:  
Right in/right out entry off NYS Route 9D and an entry off New Hamburg Road.

vi. Are public/private transportation service(s) or facilities available within 1/2 mile of the proposed site?  Yes  No

vii. Will the proposed action include access to public transportation or accommodations for use of hybrid, electric or other alternative fueled vehicles?  Yes  No

viii. Will the proposed action include plans for pedestrian or bicycle accommodations for connections to existing pedestrian or bicycle routes?  Yes  No

---

k. Will the proposed action (for commercial or industrial projects only) generate new or additional demand for energy?  Yes  No

If Yes:

i. Estimate annual electricity demand during operation of the proposed action: \_\_\_\_\_  
TBD

ii. Anticipated sources/suppliers of electricity for the project (e.g., on-site combustion, on-site renewable, via grid/local utility, or other):  
Central Hudson Gas & Electric Corp.

iii. Will the proposed action require a new, or an upgrade, to an existing substation?  Yes  No

---

l. Hours of operation. Answer all items which apply.

<p>i. During Construction:</p> <ul style="list-style-type: none"> <li>• Monday - Friday: <u>7:00 am to 7:00 pm</u></li> <li>• Saturday: <u>9:00 am to 6:00 pm</u></li> <li>• Sunday: <u>N/A</u></li> <li>• Holidays: <u>N/A</u></li> </ul>	<p>ii. During Operations:</p> <ul style="list-style-type: none"> <li>• Monday - Friday: <u>24 hours</u></li> <li>• Saturday: <u>24 hours</u></li> <li>• Sunday: <u>24 hours</u></li> <li>• Holidays: <u>24 hours</u></li> </ul>
--	---

m. Will the proposed action produce noise that will exceed existing ambient noise levels during construction, operation, or both?  Yes  No

If yes:

i. Provide details including sources, time of day and duration:  
Temporary noise above local ambient levels may occur during construction activities which will be limited to the hours of 7:00 a.m. to 7:00 p.m. on weekdays and 9:00 a.m. to 6:00 p.m. on weekends in accordance with Chapter 166 Section 166-7.C.

ii. Will the proposed action remove existing natural barriers that could act as a noise barrier or screen?  Yes  No  
 Describe: The project site is located within the developed hamlet of Hughsonville; therefore, no substantial natural barriers exist.

---

n. Will the proposed action have outdoor lighting?  Yes  No

If yes:

i. Describe source(s), location(s), height of fixture(s), direction/aim, and proximity to nearest occupied structures:  
Exterior lighting will be directed away from adjoining streets and properties and will not cause objectionable glare observable from such streets or properties.

ii. Will proposed action remove existing natural barriers that could act as a light barrier or screen?  Yes  No  
 Describe: The project site is located within the developed hamlet of Hughsonville; therefore, no substantial natural barriers exist.

---

o. Does the proposed action have the potential to produce odors for more than one hour per day?  Yes  No  
 If Yes, describe possible sources, potential frequency and duration of odor emissions, and proximity to nearest occupied structures: \_\_\_\_\_  
 \_\_\_\_\_  
 \_\_\_\_\_

---

p. Will the proposed action include any bulk storage of petroleum (combined capacity of over 1,100 gallons) or chemical products 185 gallons in above ground storage or any amount in underground storage?  Yes  No

If Yes:

i. Product(s) to be stored Gasoline, Diesel Fuel

ii. Volume(s) 2-12,000 per unit time gallon tanks (e.g., month, year)

iii. Generally, describe the proposed storage facilities: \_\_\_\_\_  
Two double-wall fiberglass underground storage tanks and piping would be installed and registered with NYSDEC.

---

q. Will the proposed action (commercial, industrial and recreational projects only) use pesticides (i.e., herbicides, insecticides) during construction or operation?  Yes  No

If Yes:

i. Describe proposed treatment(s): \_\_\_\_\_  
 \_\_\_\_\_  
 \_\_\_\_\_

ii. Will the proposed action use Integrated Pest Management Practices?  Yes  No

---

r. Will the proposed action (commercial or industrial projects only) involve or require the management or disposal of solid waste (excluding hazardous materials)?  Yes  No

If Yes:

i. Describe any solid waste(s) to be generated during construction or operation of the facility:

- Construction: \_\_\_\_\_ TBD tons per \_\_\_\_\_ one time (unit of time)
- Operation : \_\_\_\_\_ 0.55 tons per \_\_\_\_\_ month (unit of time)

ii. Describe any proposals for on-site minimization, recycling or reuse of materials to avoid disposal as solid waste:

- Construction: Demolition and construction waste may be recycled at the discretion of the contractor.
- Operation: Recyclables will be separated and stored for recycling.

iii. Proposed disposal methods/facilities for solid waste generated on-site:

- Construction: Construction and demolition debris will be hauled away by a licensed solid waste hauler for disposal at a demolition debris landfill or other licensed facility.
- Operation: Solid waste will be collected and hauled away regularly by a licensed solid waste hauler for disposal at the Dutchess County Resource Recovery Agency facility or other licensed facility.

s. Does the proposed action include construction or modification of a solid waste management facility?  Yes  No  
 If Yes:  
 i. Type of management or handling of waste proposed for the site (e.g., recycling or transfer station, composting, landfill, or other disposal activities): \_\_\_\_\_  
 ii. Anticipated rate of disposal/processing:  
 • \_\_\_\_\_ Tons/month, if transfer or other non-combustion/thermal treatment, or  
 • \_\_\_\_\_ Tons/hour, if combustion or thermal treatment  
 iii. If landfill, anticipated site life: \_\_\_\_\_ years

t. Will the proposed action at the site involve the commercial generation, treatment, storage, or disposal of hazardous waste?  Yes  No  
 If Yes:  
 i. Name(s) of all hazardous wastes or constituents to be generated, handled or managed at facility: \_\_\_\_\_  
 \_\_\_\_\_  
 ii. Generally describe processes or activities involving hazardous wastes or constituents: \_\_\_\_\_  
 \_\_\_\_\_  
 iii. Specify amount to be handled or generated \_\_\_\_\_ tons/month  
 iv. Describe any proposals for on-site minimization, recycling or reuse of hazardous constituents: \_\_\_\_\_  
 \_\_\_\_\_  
 v. Will any hazardous wastes be disposed at an existing offsite hazardous waste facility?  Yes  No  
 If Yes: provide name and location of facility: \_\_\_\_\_  
 \_\_\_\_\_  
 If No: describe proposed management of any hazardous wastes which will not be sent to a hazardous waste facility:  
 \_\_\_\_\_  
 \_\_\_\_\_

**E. Site and Setting of Proposed Action**

**E.1. Land uses on and surrounding the project site**

a. Existing land uses.  
 i. Check all uses that occur on, adjoining and near the project site.  
 Urban  Industrial  Commercial  Residential (suburban)  Rural (non-farm)  
 Forest  Agriculture  Aquatic  Other (specify): Community Services; Public Services  
 ii. If mix of uses, generally describe:  
 \_\_\_\_\_  
 \_\_\_\_\_

b. Land uses and covertypes on the project site.

Land use or Covertypes	Current Acreage	Acreage After Project Completion	Change (Acres +/-)
• Roads, buildings, and other paved or impervious surfaces	0.61	0.80	+0.19
• Forested	0.0	0.0	0.0
• Meadows, grasslands or brushlands (non-agricultural, including abandoned agricultural)	0.0	0.0	0.0
• Agricultural (includes active orchards, field, greenhouse etc.)	0.0	0.0	0.0
• Surface water features (lakes, ponds, streams, rivers, etc.)	0.0	0.0	0.0
• Wetlands (freshwater or tidal)	0.0	0.0	0.0
• Non-vegetated (bare rock, earth or fill)	0.0	0.0	0.0
• Other Describe: <u>lawn with some trees</u>	1.18	0.99	+0.2

c. Is the project site presently used by members of the community for public recreation?  Yes  No  
i. If Yes: explain: \_\_\_\_\_

d. Are there any facilities serving children, the elderly, people with disabilities (e.g., schools, hospitals, licensed day care centers, or group homes) within 1500 feet of the project site?  Yes  No  
If Yes,  
i. Identify Facilities: \_\_\_\_\_

e. Does the project site contain an existing dam?  Yes  No  
If Yes:  
i. Dimensions of the dam and impoundment:  
• Dam height: \_\_\_\_\_ feet  
• Dam length: \_\_\_\_\_ feet  
• Surface area: \_\_\_\_\_ acres  
• Volume impounded: \_\_\_\_\_ gallons OR acre-feet  
ii. Dam's existing hazard classification: \_\_\_\_\_  
iii. Provide date and summarize results of last inspection: \_\_\_\_\_

f. Has the project site ever been used as a municipal, commercial or industrial solid waste management facility, or does the project site adjoin property which is now, or was at one time, used as a solid waste management facility?  Yes  No  
If Yes:  
i. Has the facility been formally closed?  Yes  No  
• If yes, cite sources/documentation: \_\_\_\_\_  
ii. Describe the location of the project site relative to the boundaries of the solid waste management facility: \_\_\_\_\_  
iii. Describe any development constraints due to the prior solid waste activities: \_\_\_\_\_

g. Have hazardous wastes been generated, treated and/or disposed of at the site, or does the project site adjoin property which is now or was at one time used to commercially treat, store and/or dispose of hazardous waste?  Yes  No  
If Yes:  
i. Describe waste(s) handled and waste management activities, including approximate time when activities occurred: \_\_\_\_\_

h. Potential contamination history. Has there been a reported spill at the proposed project site, or have any remedial actions been conducted at or adjacent to the proposed site?  Yes  No  
If Yes:  
i. Is any portion of the site listed on the NYSDEC Spills Incidents database or Environmental Site Remediation database? Check all that apply:  Yes  No  
 Yes – Spills Incidents database Provide DEC ID number(s): \_\_\_\_\_  
 Yes – Environmental Site Remediation database Provide DEC ID number(s): \_\_\_\_\_  
 Neither database  
ii. If site has been subject of RCRA corrective activities, describe control measures: \_\_\_\_\_  
iii. Is the project within 2000 feet of any site in the NYSDEC Environmental Site Remediation database?  Yes  No  
If yes, provide DEC ID number(s): \_\_\_\_\_  
iv. If yes to (i), (ii) or (iii) above, describe current status of site(s): \_\_\_\_\_

v. Is the project site subject to an institutional control limiting property uses?  Yes  No

- If yes, DEC site ID number: \_\_\_\_\_
- Describe the type of institutional control (e.g., deed restriction or easement): \_\_\_\_\_
- Describe any use limitations: \_\_\_\_\_
- Describe any engineering controls: \_\_\_\_\_
- Will the project affect the institutional or engineering controls in place?  Yes  No
- Explain: \_\_\_\_\_  
 \_\_\_\_\_  
 \_\_\_\_\_

---

**E.2. Natural Resources On or Near Project Site**

a. What is the average depth to bedrock on the project site? \_\_\_\_\_ 1.6 to > 6.6 feet

b. Are there bedrock outcroppings on the project site?  Yes  No  
 If Yes, what proportion of the site is comprised of bedrock outcroppings? \_\_\_\_\_ %

c. Predominant soil type(s) present on project site: Dutchess-Cardigan Complex (DwB) \_\_\_\_\_ 100 %  
 \_\_\_\_\_ %  
 \_\_\_\_\_ %

d. What is the average depth to the water table on the project site? Average: \_\_\_\_\_ > 6.6 feet

e. Drainage status of project site soils:  Well Drained: \_\_\_\_\_ 100 % of site  
 Moderately Well Drained: \_\_\_\_\_ % of site  
 Poorly Drained \_\_\_\_\_ % of site

f. Approximate proportion of proposed action site with slopes:  0-10%: \_\_\_\_\_ 100 % of site  
 10-15%: \_\_\_\_\_ % of site  
 15% or greater: \_\_\_\_\_ % of site

g. Are there any unique geologic features on the project site?  Yes  No  
 If Yes, describe: \_\_\_\_\_  
 \_\_\_\_\_

h. Surface water features.

i. Does any portion of the project site contain wetlands or other waterbodies (including streams, rivers, ponds or lakes)?  Yes  No

ii. Do any wetlands or other waterbodies adjoin the project site?  Yes  No

If Yes to either *i* or *ii*, continue. If No, skip to E.2.i.

iii. Are any of the wetlands or waterbodies within or adjoining the project site regulated by any federal, state or local agency?  Yes  No

iv. For each identified regulated wetland and waterbody on the project site, provide the following information:

- Streams: Name \_\_\_\_\_ Classification \_\_\_\_\_
- Lakes or Ponds: Name \_\_\_\_\_ Classification \_\_\_\_\_
- Wetlands: Name \_\_\_\_\_ Approximate Size \_\_\_\_\_
- Wetland No. (if regulated by DEC) \_\_\_\_\_

v. Are any of the above water bodies listed in the most recent compilation of NYS water quality-impaired waterbodies?  Yes  No  
 If yes, name of impaired water body/bodies and basis for listing as impaired: \_\_\_\_\_  
 \_\_\_\_\_

---

i. Is the project site in a designated Floodway?  Yes  No

j. Is the project site in the 100-year Floodplain?  Yes  No

k. Is the project site in the 500-year Floodplain?  Yes  No

l. Is the project site located over, or immediately adjoining, a primary, principal or sole source aquifer?  Yes  No  
 If Yes:  
 i. Name of aquifer: \_\_\_\_\_

m. Identify the predominant wildlife species that occupy or use the project site: \_\_\_\_\_  
Common Dutchess County species \_\_\_\_\_  
\_\_\_\_\_

n. Does the project site contain a designated significant natural community?  Yes  No  
If Yes:  
i. Describe the habitat/community (composition, function, and basis for designation): \_\_\_\_\_  
ii. Source(s) of description or evaluation: \_\_\_\_\_  
iii. Extent of community/habitat:  
• Currently: \_\_\_\_\_ acres  
• Following completion of project as proposed: \_\_\_\_\_ acres  
• Gain or loss (indicate + or -): \_\_\_\_\_ acres

o. Does project site contain any species of plant or animal that is listed by the federal government or NYS as endangered or threatened, or does it contain any areas identified as habitat for an endangered or threatened species?  Yes  No  
If Yes:  
i. Species and listing (endangered or threatened): \_\_\_\_\_  
Bald Eagle, Indiana Bat (NYSDEC); Northern Long-eared Bat and Indiana Bat (USFWS)

p. Does the project site contain any species of plant or animal that is listed by NYS as rare, or as a species of special concern?  Yes  No  
If Yes:  
i. Species and listing: \_\_\_\_\_

q. Is the project site or adjoining area currently used for hunting, trapping, fishing or shell fishing?  Yes  No  
If yes, give a brief description of how the proposed action may affect that use: \_\_\_\_\_

**E.3. Designated Public Resources On or Near Project Site**

a. Is the project site, or any portion of it, located in a designated agricultural district certified pursuant to Agriculture and Markets Law, Article 25-AA, Section 303 and 304?  Yes  No  
If Yes, provide county plus district name/number: \_\_\_\_\_

b. Are agricultural lands consisting of highly productive soils present?  Yes  No  
i. If Yes: acreage(s) on project site? \_\_\_\_\_  
ii. Source(s) of soil rating(s): \_\_\_\_\_

c. Does the project site contain all or part of, or is it substantially contiguous to, a registered National Natural Landmark?  Yes  No  
If Yes:  
i. Nature of the natural landmark:  Biological Community  Geological Feature  
ii. Provide brief description of landmark, including values behind designation and approximate size/extent: \_\_\_\_\_

d. Is the project site located in or does it adjoin a state listed Critical Environmental Area?  Yes  No  
If Yes:  
i. CEA name: \_\_\_\_\_  
ii. Basis for designation: \_\_\_\_\_  
iii. Designating agency and date: \_\_\_\_\_

e. Does the project site contain, or is it substantially contiguous to, a building, archaeological site, or district which is listed on the National or State Register of Historic Places, or that has been determined by the Commissioner of the NYS Office of Parks, Recreation and Historic Preservation to be eligible for listing on the State Register of Historic Places?	<input type="checkbox"/> Yes <input checked="" type="checkbox"/> No
If Yes: i. Nature of historic/archaeological resource: <input type="checkbox"/> Archaeological Site <input type="checkbox"/> Historic Building or District ii. Name: _____ iii. Brief description of attributes on which listing is based: _____	
f. Is the project site, or any portion of it, located in or adjacent to an area designated as sensitive for archaeological sites on the NY State Historic Preservation Office (SHPO) archaeological site inventory?	<input checked="" type="checkbox"/> Yes <input type="checkbox"/> No
g. Have additional archaeological or historic site(s) or resources been identified on the project site?	<input type="checkbox"/> Yes <input checked="" type="checkbox"/> No
If Yes: i. Describe possible resource(s): _____ ii. Basis for identification: _____	
h. Is the project site within five miles of any officially designated and publicly accessible federal, state, or local scenic or aesthetic resource?	<input checked="" type="checkbox"/> Yes <input type="checkbox"/> No
If Yes: i. Identify resource: <u>State and National Register Listed resources, State parks, State and County recreation areas, Town parks, SASS</u> ii. Nature of, or basis for, designation (e.g., established highway overlook, state or local park, state historic trail or scenic byway, etc.): <u>Varies, see Figure 9.</u> iii. Distance between project and resource: _____ <u>Varies, see Figure 9</u> miles.	
i. Is the project site located within a designated river corridor under the Wild, Scenic and Recreational Rivers Program 6 NYCRR 666?	<input type="checkbox"/> Yes <input checked="" type="checkbox"/> No
If Yes: i. Identify the name of the river and its designation: _____ ii. Is the activity consistent with development restrictions contained in 6NYCRR Part 666?	
<input type="checkbox"/> Yes <input type="checkbox"/> No	

**F. Additional Information**

Attach any additional information which may be needed to clarify your project.

If you have identified any adverse impacts which could be associated with your proposal, please describe those impacts plus any measures which you propose to avoid or minimize them.

**G. Verification**

I certify that the information provided is true to the best of my knowledge.

Applicant/Sponsor Name Gas Land Petroleum, Inc. (Zeidan Nesheiwat) Date 7/16/2021

Signature Caren LoBrutto, Agent for Applicant  Title Chazen Companies, Senior Planner

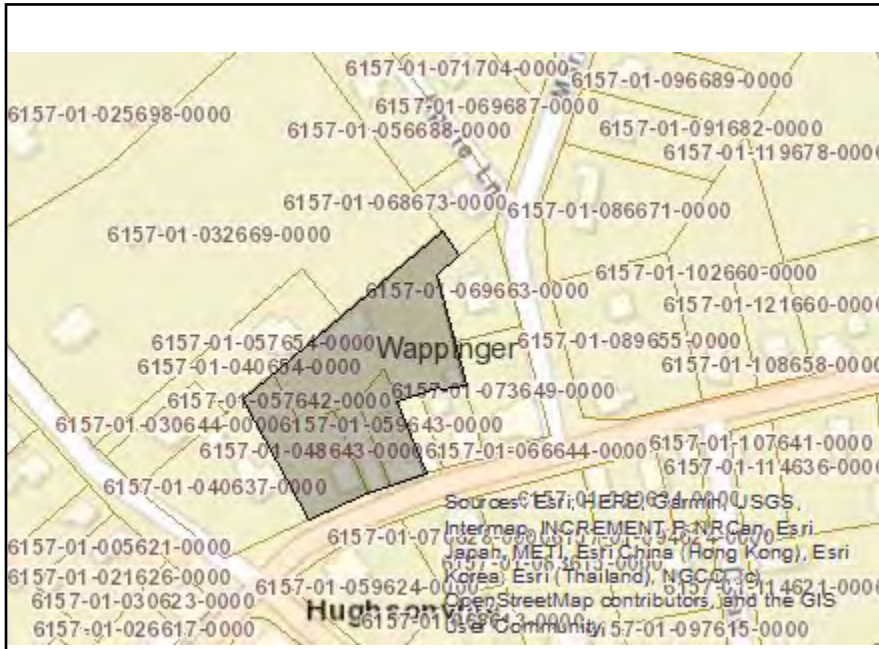

**Disclaimer:** The EAF Mapper is a screening tool intended to assist project sponsors and reviewing agencies in preparing an environmental assessment form (EAF). Not all questions asked in the EAF are answered by the EAF Mapper. Additional information on any EAF question can be obtained by consulting the EAF Workbooks. Although the EAF Mapper provides the most up-to-date digital data available to DEC, you may also need to contact local or other data sources in order to obtain data not provided by the Mapper. Digital data is not a substitute for agency determinations.



B.i.i [Coastal or Waterfront Area]	Yes
B.i.ii [Local Waterfront Revitalization Area]	No
C.2.b. [Special Planning District]	Digital mapping data are not available or are incomplete. Refer to EAF Workbook.
E.1.h [DEC Spills or Remediation Site - Potential Contamination History]	Digital mapping data are not available or are incomplete. Refer to EAF Workbook.
E.1.h.i [DEC Spills or Remediation Site - Listed]	Digital mapping data are not available or are incomplete. Refer to EAF Workbook.
E.1.h.i [DEC Spills or Remediation Site - Environmental Site Remediation Database]	Digital mapping data are not available or are incomplete. Refer to EAF Workbook.
E.1.h.iii [Within 2,000' of DEC Remediation Site]	No
E.2.g [Unique Geologic Features]	No
E.2.h.i [Surface Water Features]	No
E.2.h.ii [Surface Water Features]	No
E.2.h.iii [Surface Water Features]	No
E.2.h.v [Impaired Water Bodies]	No
E.2.i. [Floodway]	No
E.2.j. [100 Year Floodplain]	No
E.2.k. [500 Year Floodplain]	No
E.2.l. [Aquifers]	No
E.2.n. [Natural Communities]	No
E.2.o. [Endangered or Threatened Species]	Yes
E.2.o. [Endangered or Threatened Species - Name]	Bald Eagle, Indiana Bat

E.2.p. [Rare Plants or Animals]	No
E.3.a. [Agricultural District]	No
E.3.c. [National Natural Landmark]	No
E.3.d [Critical Environmental Area]	No
E.3.e. [National or State Register of Historic Places or State Eligible Sites]	Digital mapping data are not available or are incomplete. Refer to EAF Workbook.
E.3.f. [Archeological Sites]	Yes
E.3.i. [Designated River Corridor]	No



## FIGURES

---



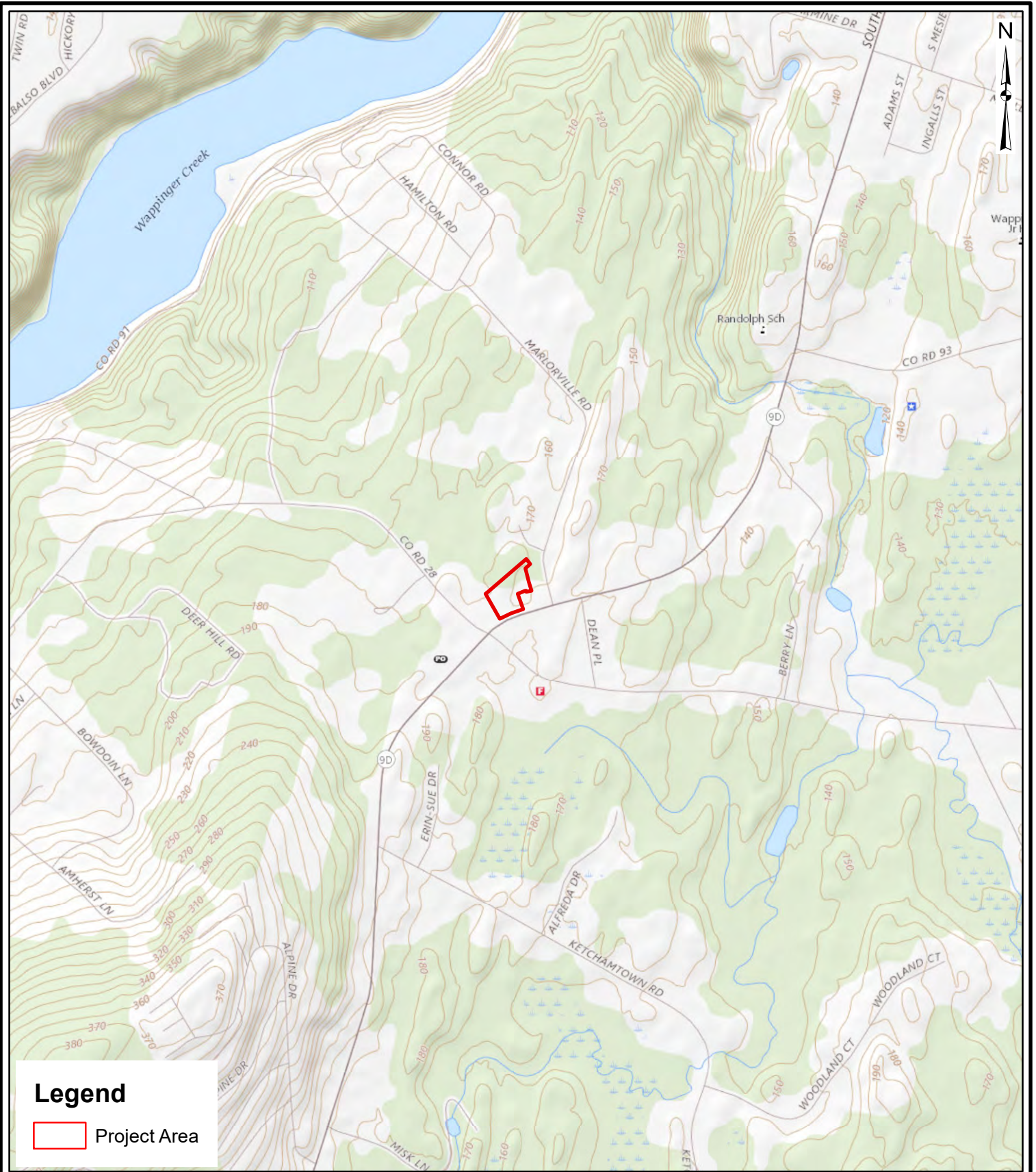

**Legend**

 Project Area

**THE Chazen COMPANIES**  
ENGINEERS  
 LAND SURVEYORS  
 PLANNERS  
 ENVIRONMENTAL & SAFETY PROFESSIONALS  
 LANDSCAPE ARCHITECTS

**Dutchess County Office:**  
 21 Fox Street, Poughkeepsie, NY 12601  
 Phone: (845) 454-3980

**Capital District Office:**  
 547 River Street, Troy, NY 12180  
 Phone: (518) 273-0055

**North Country Office:**  
 20 Elm St, Suite 110  
 Glens Falls, NY 12801  
 Phone: (518) 812-0513

**Route 9D - Gas Land Petroleum**

**USGS Location Map**

Rpute 9D, Town of Wappinger - Dutchess County, NY

Drawn:	SPL
Date:	12/23/19
Scale:	1 in = 833.3 feet
Project:	81941.00
Figure:	1



**Dutchess County Office:**  
21 Fox Street, Poughkeepsie, NY 12601  
Phone: (845) 454-3980

**Capital District Office:**  
547 River Street, Troy, NY 12180  
Phone: (518) 273-0055

**North Country Office:**  
20 Elm St, Suite 110  
Glens Falls, NY 12801  
Phone: (518) 812-0513

**Route 9D - Gas Land Petroleum**

**Orthophoto Tax Map**

Route 9D, Town of Wappinger - Dutchess County NY

Drawn:	RL-B
Date:	12/19/2019
Scale:	1 in = 80 feet
Project:	81941.00
Figure:	2

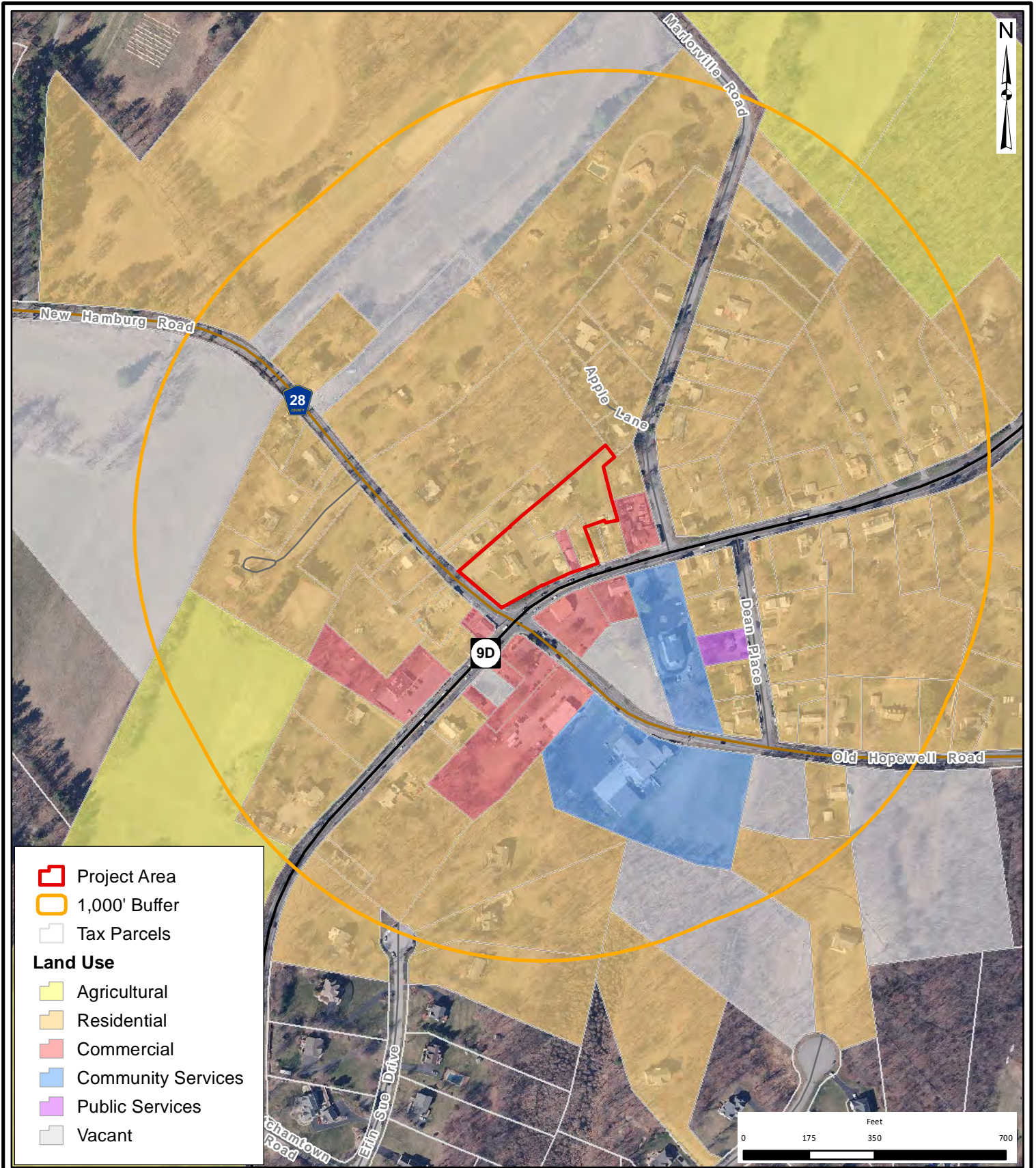

Project Area  
 1,000' Buffer  
 Tax Parcels  
**Land Use**  
 Agricultural  
 Residential  
 Commercial  
 Community Services  
 Public Services  
 Vacant

**THE**  
**Chazen**  
**COMPANIES**  
ENGINEERS  
 LAND SURVEYORS  
 PLANNERS  
 ENVIRONMENTAL & SAFETY PROFESSIONALS  
 LANDSCAPE ARCHITECTS

**Dutchess County Office:**  
 21 Fox Street, Poughkeepsie, NY 12601  
 Phone: (845) 454-3980  
**Capital District Office:**  
 547 River Street, Troy, NY 12180  
 Phone: (518) 273-0055  
**North Country Office:**  
 20 Elm St, Suite 110  
 Glens Falls, NY 12801  
 Phone: (518) 812-0513

**Route 9D - Gas Land Petroleum**

**Land Use**

Route 9D, Town of Wappinger - Dutchess County NY

Drawn:	RL-B
Date:	12/19/2019
Scale:	1 in = 350 feet
Project:	81941.00
Figure:	3

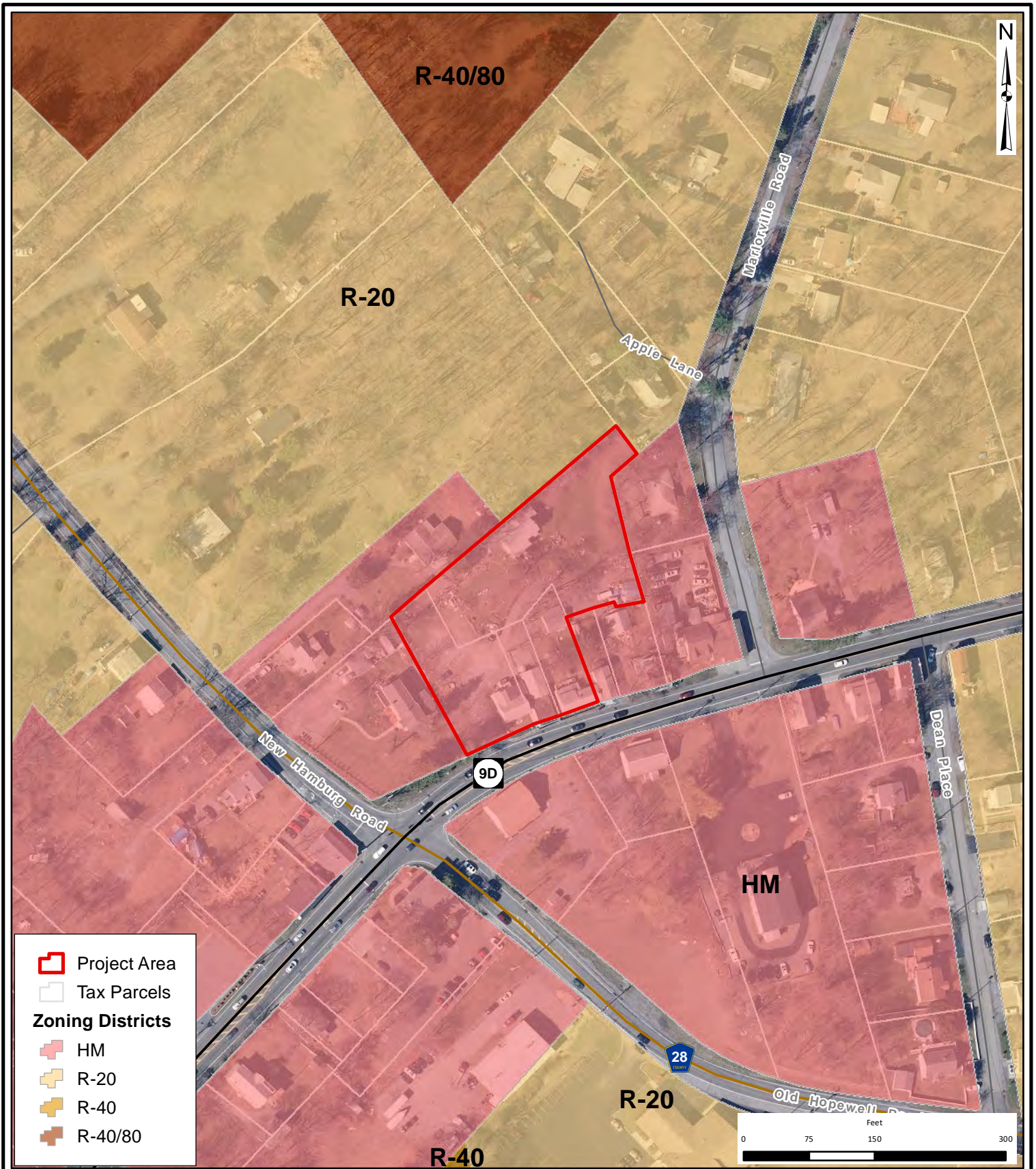

**THE Chazen COMPANIES**  
ENGINEERS  
 LAND SURVEYORS  
 PLANNERS  
 ENVIRONMENTAL & SAFETY PROFESSIONALS  
 LANDSCAPE ARCHITECTS

**Dutchess County Office:**  
 21 Fox Street, Poughkeepsie, NY 12601  
 Phone: (845) 454-3980

**Capital District Office:**  
 547 River Street, Troy, NY 12180  
 Phone: (518) 273-0055

**North Country Office:**  
 20 Elm St, Suite 110  
 Glens Falls, NY 12801  
 Phone: (518) 812-0513



**Route 9D - Gas Land Petroleum**

**Zoning**

Route 9D, Town of Wappinger - Dutchess County NY

Drawn:	RL-B
Date:	12/19/2019
Scale:	1 in = 150 feet
Project:	81941.00
Figure:	4



 Project Area  
 Tax Parcels  
**Soils**  
 DwB: Dutchess-Car... complex, undulating, rocky

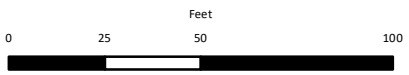

**THE Chazen COMPANIES**  
ENGINEERS  
 LAND SURVEYORS  
 PLANNERS  
 ENVIRONMENTAL & SAFETY PROFESSIONALS  
 LANDSCAPE ARCHITECTS  
**Dutchess County Office:**  
 21 Fox Street, Poughkeepsie, NY 12601  
 Phone: (845) 454-3980  
**Capital District Office:**  
 547 River Street, Troy, NY 12180  
 Phone: (518) 273-0055  
**North Country Office:**  
 20 Elm St, Suite 110  
 Glens Falls, NY 12801  
 Phone: (518) 812-0513

**Route 9D - Gas Land Petroleum**  
  
**Soils**  
  
 Route 9D, Town of Wappinger - Dutchess County NY

Drawn:	RL-B
Date:	12/19/2019
Scale:	1 in = 50 feet
Project:	81941.00
Figure:	5

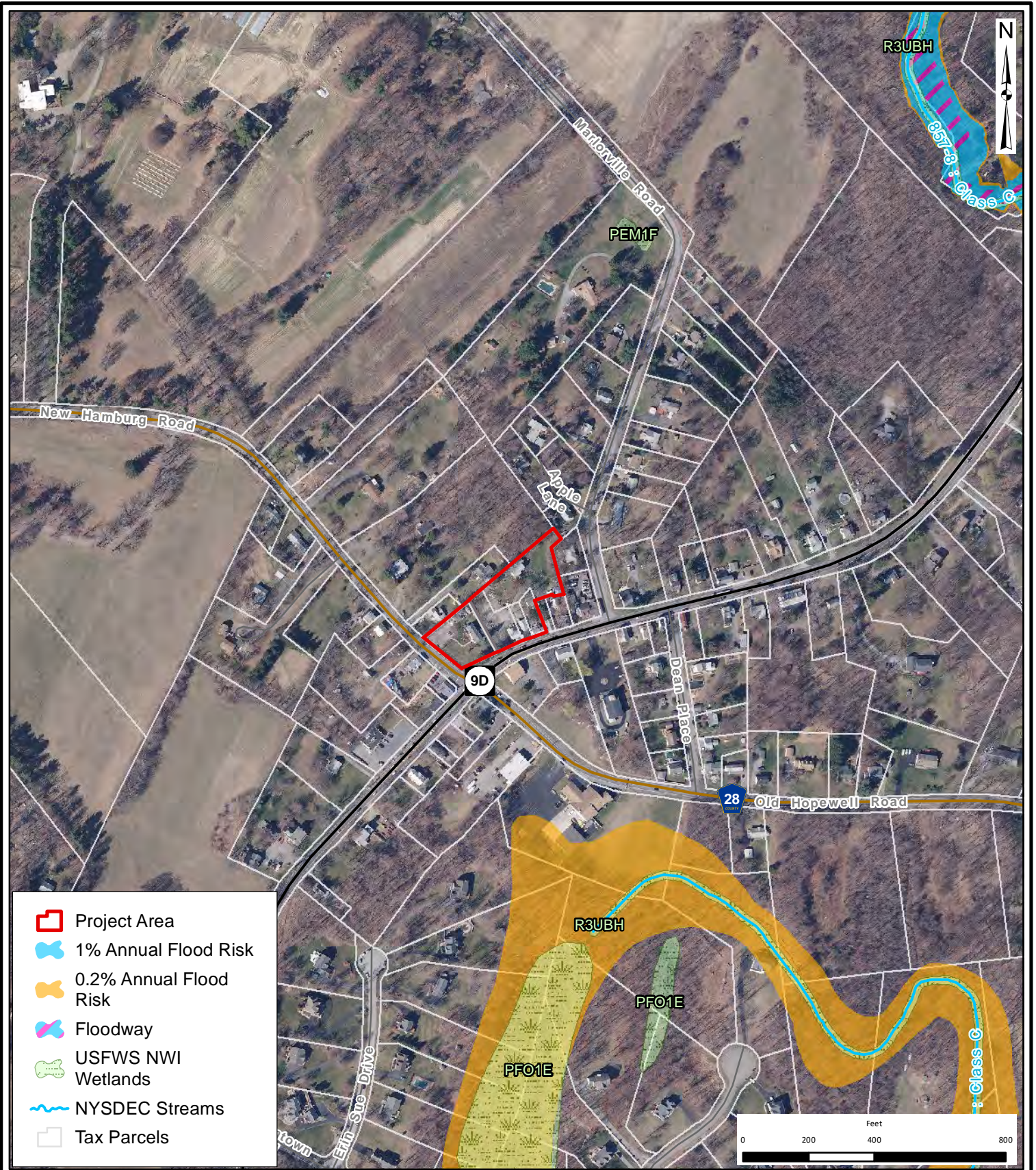

**THE Chazen COMPANIES**  
ENGINEERS  
 LAND SURVEYORS  
 PLANNERS  
 ENVIRONMENTAL & SAFETY PROFESSIONALS  
 LANDSCAPE ARCHITECTS

**Dutchess County Office:**  
 21 Fox Street, Poughkeepsie, NY 12601  
 Phone: (845) 454-3980

**Capital District Office:**  
 547 River Street, Troy, NY 12180  
 Phone: (518) 273-0055

**North Country Office:**  
 20 Elm St, Suite 110  
 Glens Falls, NY 12801  
 Phone: (518) 812-0513

**Route 9D - Gas Land Petroleum**

**Wetlands, Streams and Floodplain**

Route 9D, Town of Wappinger - Dutchess County NY

Drawn:	RL-B
Date:	12/19/2019
Scale:	1 in = 400 feet
Project:	81941.00
Figure:	6

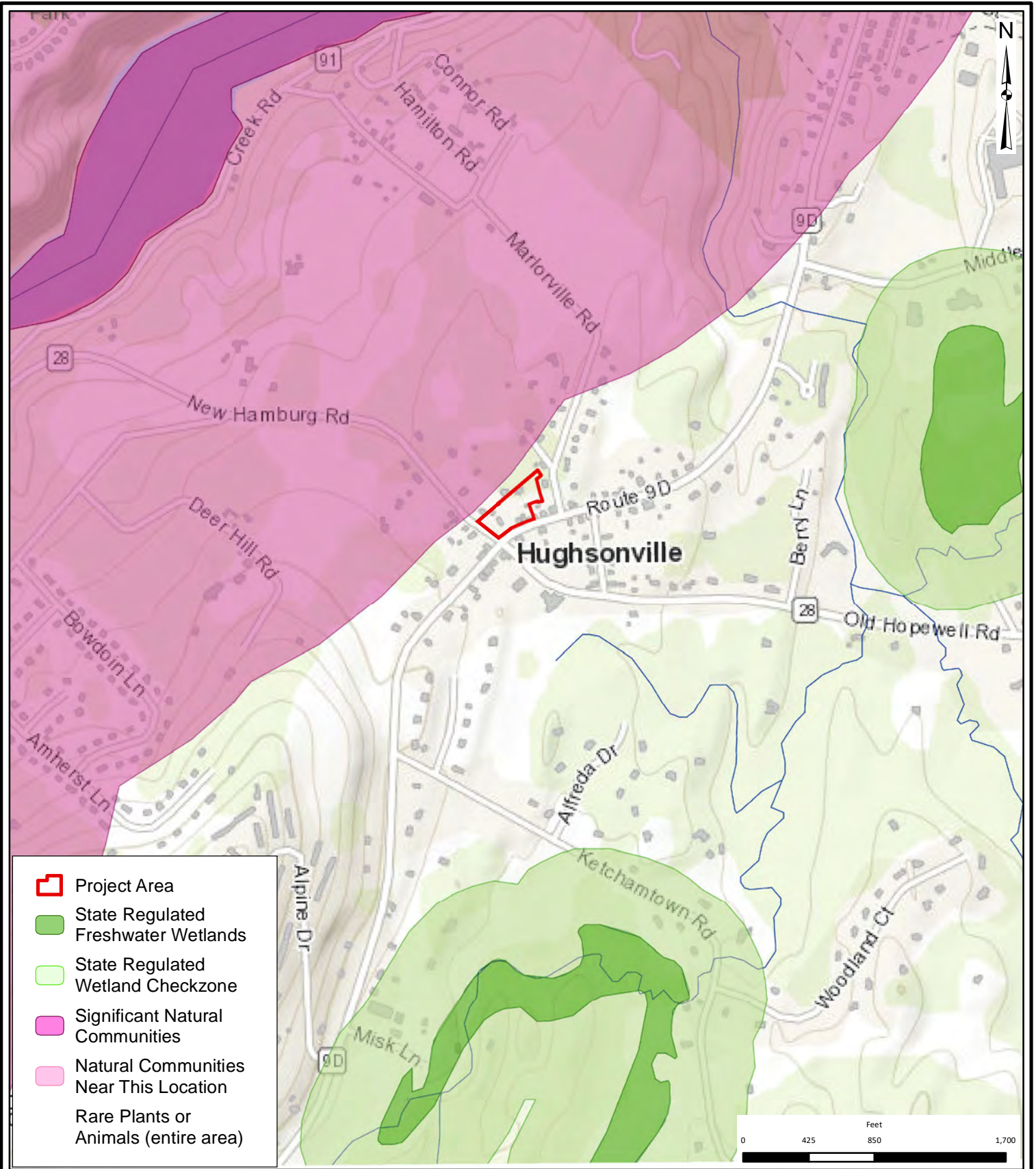

- Project Area
- State Regulated Freshwater Wetlands
- State Regulated Wetland Checkzone
- Significant Natural Communities
- Natural Communities Near This Location
- Rare Plants or Animals (entire area)

**THE Chazen COMPANIES**  
ENGINEERS  
 LAND SURVEYORS  
 ENVIRONMENTAL & SAFETY PROFESSIONALS  
 PLANNERS  
 LANDSCAPE ARCHITECTS

**Dutchess County Office:**  
 21 Fox Street, Poughkeepsie, NY 12601  
 Phone: (845) 454-3980

**Capital District Office:**  
 547 River Street, Troy, NY 12180  
 Phone: (518) 273-0055

**North Country Office:**  
 20 Elm St, Suite 110  
 Glens Falls, NY 12801  
 Phone: (518) 812-0513

**Route 9D - Gas Land Petroleum**

**NYSDEC Environmental Resource Map**

Route 9D, Town of Wappinger - Dutchess County NY

Drawn:	RL-B
Date:	12/19/2019
Scale:	1 in = 850 feet
Project:	81941.00
Figure:	7

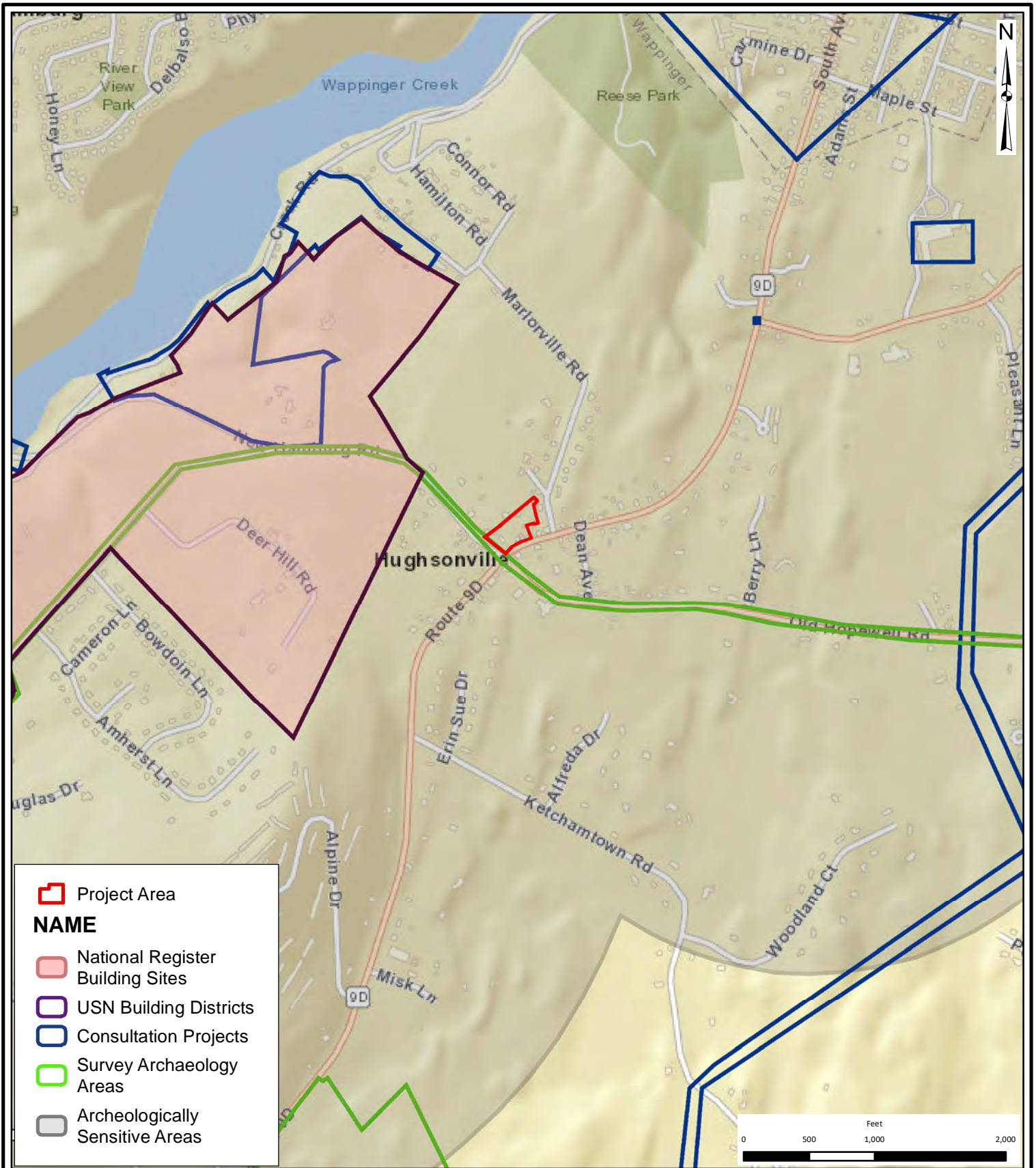



 Project Area

**NAME**

 National Register Building Sites

 USN Building Districts

 Consultation Projects

 Survey Archaeology Areas

 Archeologically Sensitive Areas

**THE Chazen COMPANIES**  
ENGINEERS  
 LAND SURVEYORS  
 ENVIRONMENTAL & SAFETY PROFESSIONALS  
 PLANNERS  
 LANDSCAPE ARCHITECTS

**Dutchess County Office:**  
 21 Fox Street, Poughkeepsie, NY 12601  
 Phone: (845) 454-3980

**Capital District Office:**  
 547 River Street, Troy, NY 12180  
 Phone: (518) 273-0055

**North Country Office:**  
 20 Elm St, Suite 110  
 Glens Falls, NY 12801  
 Phone: (518) 812-0513

**Route 9D - Gas Land Petroleum**

**NYSOPRHP Cultural Resource Information System (CRIS) Map**

Route 9D, Town of Wappinger - Dutchess County NY

Drawn:	RL-B
Date:	12/19/2019
Scale:	1 in = 1,000 feet
Project:	81941.00
Figure:	8

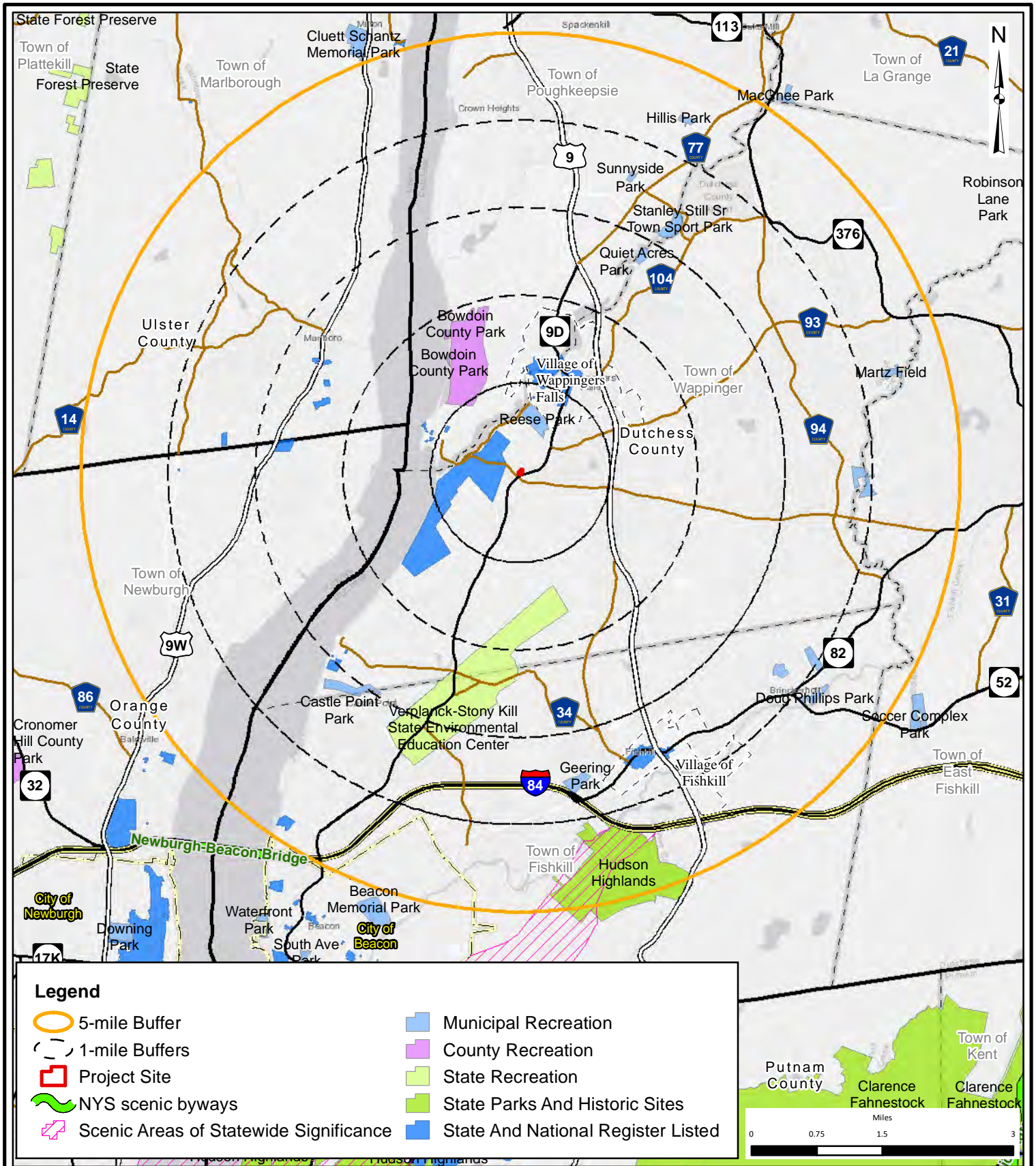

**Dutchess County Office:**  
 21 Fox Street, Poughkeepsie, NY 12601  
 Phone: (845) 454-3980

**Capital District Office:**  
 547 River Street, Troy, NY 12180  
 Phone: (518) 273-0055

**North Country Office:**  
 20 Elm St, Suite 110  
 Glens Falls, NY 12801  
 Phone: (518) 812-0513

**Route 9D - Gas Land Petroleum**

**Publicly Accessible  
 Federal, State, or Local Scenic or Aesthetic  
 Resources within 5 Miles**

Route 9D, Town of Wappinger - Dutchess County NY

Drawn:	RL-B
Date:	12/19/2019
Scale:	1 in = 1.5 miles
Project:	81941.00
Figure:	9



**ATTACHMENT A**  
**Suffolk County Loading Rates**

---



COUNTY OF SUFFOLK



STEVEN BELLONE  
SUFFOLK COUNTY EXECUTIVE

SUFFOLK COUNTY  
DEPARTMENT OF HEALTH SERVICES  
DIVISION OF ENVIRONMENTAL QUALITY

**STANDARDS FOR APPROVAL OF PLANS  
AND CONSTRUCTION FOR  
SEWAGE DISPOSAL SYSTEMS FOR  
OTHER THAN SINGLE-FAMILY RESIDENCES**

Originally Issued on July 15, 2008

James L. Tomarken, MD, MPH, MBA, MSW  
Commissioner of Health Services

Walter Dawydiak, PE, JD  
Acting Director of Environmental Quality

**TABLE 1 - PROJECT DENSITY LOADING RATES & DESIGN SEWAGE FLOW RATES**  
(Based upon gross floor area in square feet (sf) unless otherwise noted)

Structure Use	Density Load	Kitchen/Gray Load	Hydraulic Load
<b>FOOD SERVICE</b>			
Bar (in restaurant)	10 gpd/seat	5 gpd/seat	15 gpd/seat
Bar, Tavern, Disco (no fixed seating)	10 gpd/occupant <sup>1</sup>	5 gpd/occupant <sup>1</sup>	15 gpd/occupant <sup>1</sup>
Bar (outdoor/seasonal)	5 gpd/seat	2.5 gpd/seat	7.5 gpd/seat
Cafeteria (open to public)	See Primary use + 5 gpd/seat	2.5 gpd/seat	Primary use + 7.5 gpd/seat
Cafeteria/Continental Breakfast (not open to public)	See Primary Use	2.5 gpd/seat	Primary use + 2.5 gpd/seat
Snack Bar	See Primary Use	0.12 gpd/sf	Primary use + 0.12 gpd/sf
Juice Bar	See Primary Use	2.5 gpd/seat	Primary use + 2.5 gpd/seat
Catering Hall	5 gpd/seat	2.5 gpd/seat	7.5 gpd/seat
Outside Patio Dining	5 gpd/seat	10 gpd/seat	15 gpd/seat
Restaurant (full service or single services > 16 seats <sup>2</sup> )	10 gpd/seat	20 gpd/seat	30 gpd/seat
Wet store w/ food (Deli/take-out with max 16 seats single service <sup>2</sup> )	0.03 gpd/sf	0.12 gpd/sf	0.15 gpd/sf
Convenience store/Market/Farm Stand	0.03 gpd/sf	0.02 gpd/sf	0.05 gpd/sf
Commercial Bakery	0.04 gpd/sf	0.02 gpd/sf	0.06 gpd/sf
Wine/Beer Tasting (in a winery/brewery only)	5 gpd/occ	2.5 gpd/occ	7.5 gpd/occ
<b>GENERAL INDUSTRIAL</b>			
General Industrial <sup>3</sup>	0.04 gpd/sf	Industrial process water <sup>4</sup>	0.04 gpd/sf
Greenhouse	0.03 gpd/sf	N/A	0.03 gpd/sf
<b>MEDICAL</b>			
Drug Rehabilitation	75 gpd/bed	See note <sup>5</sup>	75 gpd/bed
Mental Health Residence	75 gpd/bed	See note <sup>5</sup>	75 gpd/bed
Hospital	300 gpd/bed	See note <sup>5</sup>	300 gpd/bed
Nursing Home	150 gpd/bed	See note <sup>5</sup>	150 gpd/bed
Assisted Living	110 gpd/bed	See note <sup>5</sup>	110 gpd/bed
Medical office space	0.10 gpd/sf	N/A	0.10 gpd/sf
Dialysis Center	0.10 gpd/sf	Dialysis process water <sup>4</sup>	0.10 gpd/sf
Veterinary <sup>6</sup>	0.10 gpd/sf + 10 gpd/animal boarding	N/A	0.10 gpd/sf + 10 gpd/animal boarding

<b>MUNICIPAL SERVICES</b>			
Library, firehouse, precinct, museum, art gallery (w/ meeting rooms)	0.03 gpd/sf + 5 gpd/occupant <sup>1</sup> for meeting rooms	2.5 gpd/occupant <sup>1</sup>	0.03 gpd/sf + 5 gpd/occupant <sup>1</sup> + 2.5 gpd/occupant <sup>1</sup>
Library, firehouse, precinct, museum, art gallery (w/o meeting rooms)	0.03 gpd/sf	2.5 gpd/occupant <sup>1</sup>	0.03 gpd/sf + 2.5 gpd/occupant <sup>1</sup>
<b>OFFICE</b>			
Non-medical office space	0.06 gpd/sf		0.06 gpd/sf
<b>RECREATION</b>			
Bath house/comfort station	5 gpd/occupant <sup>1</sup>	5 gpd/shower/occupant <sup>1</sup> + Food service <sup>7</sup>	5 gpd/occupant <sup>1</sup> + 5 gpd/shower/occupant + Food service <sup>7</sup>
Bowling alley/tennis court/racquetball	100 gpd/court or alley	Food service <sup>7</sup>	100 gpd/court or alley + Food service <sup>7</sup>
Miniature golf	15 gpd/parking space	Food service <sup>7</sup>	15 gpd/parking space + Food service <sup>7</sup>
Ice/roller Skating Rink	15 gpd/skater <sup>1</sup> + 5 gpd/specator <sup>1</sup>	Food service <sup>7</sup>	15 gpd/skater <sup>1</sup> + 5 gpd/specator <sup>1</sup> + Food service <sup>7</sup>
Recreation	15 gpd/parking space	Food service <sup>7</sup>	15 gpd/parking space + Food service <sup>7</sup>
Spa/Fitness Center/ Karate/Dance/etc. (w/ showers & amenities)	0.1 gpd/sf	0.2 gpd/sf + Food service <sup>7</sup>	0.3 gpd/sf + Food service <sup>7</sup>
Spa/Fitness Center/ Karate/Dance/etc. (w/o showers & amenities)	0.1 gpd/sf	Food service <sup>7</sup>	0.1 gpd/sf + Food service <sup>7</sup>
Marina	10 gpd/boat slip	Food service <sup>7</sup>	10 gpd/boat slip + Food service <sup>7</sup>
OTB	5 gpd/person	Food service <sup>7</sup>	5 gpd/person + Food service <sup>7</sup>
Theater	3 gpd/seat	Food service <sup>7</sup>	3 gpd/seat + Food service <sup>7</sup>
Horse Farm <sup>6</sup>	0.04 gpd/sf + 10 gpd/stall		0.04 gpd/sf + 10 gpd/stall
Camp Ground	10 gpd/camper	5 gpd/shower/camper	10 gpd/camper + 5 gpd/shower/camper
Billiard Hall	5 gpd/occ	2.5 gpd/occ	7.5 gpd/occ
<b>RESIDENTIAL</b>			
Single Family Residence	300 gpd		300 gpd
Two Family Residence	600 gpd		600 gpd
Rooming house	75 gpd/bed		75 gpd/bed

Motel/Hotel unit up to 400 sq.ft. gross floor area w/o kitchenette (w/kitchenette see Housing Unit)	100 gpd/unit		100 gpd/unit
Motel/Hotel unit > 400 sq.ft. gross floor area w/o kitchenette (w/kitchenette see Housing Unit)	150 gpd/unit		150 gpd/unit
Housing Unit <sup>8</sup> up to 600 sq.ft. gross floor area	150 gpd/unit		150 gpd/unit
Housing Unit <sup>8</sup> between 601-1200 sq.ft. gross floor area	225 gpd/unit		225 gpd/unit
Housing Unit <sup>8</sup> > 1200 sq.ft. gross floor area	300 gpd/unit		300 gpd/unit
PRC unit up to 600 sq.ft. gross floor area	100 gpd/unit		100 gpd/unit
PRC unit between 600-1600 sq.ft. gross floor area	150 gpd/unit		150 gpd/unit
PRC unit between 1600-2000 sq.ft. gross floor area	225 gpd/unit		225 gpd/unit
PRC unit > 2000 sq.ft. gross floor area	300 gpd/unit		300 gpd/unit
<b>RETAIL</b>			
Dry store	0.03 gpd/sf		0.03 gpd/sf
Wet store w/o Food (Hair salon, nail salon, pet shop w/o animal boarding etc.)	0.03 gpd/sf	0.07 gpd/sf	0.1 gpd/sf
Car Dealership	0.03 gpd/sf for showroom/offices + 0.04 gpd/sf for maintenance/storage areas		0.03 gpd/sf for showroom/offices + 0.04 gpd/sf for maintenance/storage areas
Massage/Tanning	0.03 gpd/sf		0.03 gpd/sf
Tattoo Parlor	0.03 gpd/sf		0.03 gpd/sf
<b>SCHOOL</b>			
Boarding school/Dormitory	75 gpd/capita <sup>1</sup>	2.5 gpd/capita <sup>1</sup>	77.5 gpd/capita <sup>1</sup>
Day School	5 gpd/capita <sup>1</sup>	2.5 gpd/capita <sup>1</sup>	7.5 gpd/capita <sup>1</sup>
<b>MISCELLANEOUS</b>			
Car Wash	0.04 gpd/sf	Car wash process water <sup>4</sup>	0.04 gpd/sf
Laundromat	0.03 gpd/sf	Laundromat process water <sup>4</sup>	0.03 gpd/sf

Funeral Home	0.05 gpd/sf	Funeral Home process water <sup>4</sup>	0.05 gpd/sf
House of Worship (w/ meeting rooms)	1.5 gpd/seat + 5 gpd/occupant <sup>1</sup> for meeting rooms	2.5 gpd/occupant <sup>1</sup>	1.5 gpd/seat + 5 gpd/occupant <sup>1</sup> + 2.5 gpd/occupant <sup>1</sup>
House of Worship (w/o meeting rooms)	1.5 gpd/seat	2.5 gpd/occupant <sup>1</sup>	1.5 gpd/seat + 2.5 gpd/occupant <sup>1</sup>
Public Storage <sup>9</sup>	0.04 gpd/sf		0.04 gpd/sf
Animal boarding <sup>6</sup>	0.03 gpd/sf + 10 gpd/animal		0.03 gpd/sf + 10 gpd/animal
Winery/Brewery	0.04 gpd/sf	Winery/Brewery process water <sup>4</sup>	0.04 gpd/sf

<sup>1</sup> Occupancy ratings can be determined using New York State Uniform Fire Prevention and Building Code as a guide.

<sup>2</sup> Single Service means disposable plates, silverware & cups. Takeout seating is for waiting patrons and is not convertible to full seating or for density credit at full service restaurants.

<sup>3</sup> General industrial buildings may contain up to 15% related office space without applying a proportionate office density loading or flow rating to the space. If office space exceeds 15% of gross floor area, then a proportionate office density loading or flow rating must be applied to the entire office space.

<sup>4</sup> Process waters require a separate permit and disposal facilities – Consult Department.

<sup>5</sup> A grease trap shall be provided for this installation which is sized at 20 gpd/bed.

<sup>6</sup> A separate sewage disposal system shall be provided for wastewater generated from animal boarding, horse stalls, or kennel areas.

<sup>7</sup> Food (kitchen) flow is added according to the type of food service in the establishment.

<sup>8</sup> Motel/Hotel with Kitchenettes, Cottages, Apartments, Condominiums, Mobile Homes, Trailers, or Co-Ops.

<sup>9</sup> Public storage density and/or design flow may be reduced if restrictive covenants are recorded on the parcel.

**Note:** The above table is subject to amendment from time to time as data becomes available to the Department. The table will be republished as an addendum to these standards if and when revised.



**ATTACHMENT B**  
**USFWS IPAC Information**

---



# IPaC resource list

This report is an automatically generated list of species and other resources such as critical habitat (collectively referred to as *trust resources*) under the U.S. Fish and Wildlife Service's (USFWS) jurisdiction that are known or expected to be on or near the project area referenced below. The list may also include trust resources that occur outside of the project area, but that could potentially be directly or indirectly affected by activities in the project area. However, determining the likelihood and extent of effects a project may have on trust resources typically requires gathering additional site-specific (e.g., vegetation/species surveys) and project-specific (e.g., magnitude and timing of proposed activities) information.

Below is a summary of the project information you provided and contact information for the USFWS office(s) with jurisdiction in the defined project area. Please read the introduction to each section that follows (Endangered Species, Migratory Birds, USFWS Facilities, and NWI Wetlands) for additional information applicable to the trust resources addressed in that section.

## Location

Dutchess County, New York



## Local office

New York Ecological Services Field Office

☎ (607) 753-9334

📠 (607) 753-9699

3817 Luker Road  
Cortland, NY 13045-9385

<http://www.fws.gov/northeast/nyfo/es/section7.htm>

# Endangered species

**This resource list is for informational purposes only and does not constitute an analysis of project level impacts.**

The primary information used to generate this list is the known or expected range of each species. Additional areas of influence (AOI) for species are also considered. An AOI includes areas outside of the species range if the species could be indirectly affected by activities in that area (e.g., placing a dam upstream of a fish population even if that fish does not occur at the dam site, may indirectly impact the species by reducing or eliminating water flow downstream). Because species can move, and site conditions can change, the species on this list are not guaranteed to be found on or near the project area. To fully determine any potential effects to species, additional site-specific and project-specific information is often required.

Section 7 of the Endangered Species Act **requires** Federal agencies to "request of the Secretary information whether any species which is listed or proposed to be listed may be present in the area of such proposed action" for any project that is conducted, permitted, funded, or licensed by any Federal agency. A letter from the local office and a species list which fulfills this requirement can **only** be obtained by requesting an official species list from either the Regulatory Review section in IPaC (see directions below) or from the local field office directly.

For project evaluations that require USFWS concurrence/review, please return to the IPaC website and request an official species list by doing the following:

1. Draw the project location and click CONTINUE.
2. Click DEFINE PROJECT.
3. Log in (if directed to do so).
4. Provide a name and description for your project.
5. Click REQUEST SPECIES LIST.

Listed species<sup>1</sup> and their critical habitats are managed by the [Ecological Services Program](#) of the U.S. Fish and Wildlife Service (USFWS) and the fisheries division of the National Oceanic and Atmospheric Administration (NOAA Fisheries<sup>2</sup>).

Species and critical habitats under the sole responsibility of NOAA Fisheries are **not** shown on this list. Please contact [NOAA Fisheries](#) for [species under their jurisdiction](#).

1. Species listed under the [Endangered Species Act](#) are threatened or endangered; IPaC also shows species that are candidates, or proposed, for listing. See the [listing status page](#) for more information. IPaC only shows species that are regulated by USFWS (see FAQ).
2. [NOAA Fisheries](#), also known as the National Marine Fisheries Service (NMFS), is an office of the National Oceanic and Atmospheric Administration within the Department of Commerce.

The following species are potentially affected by activities in this location:

## Mammals

NAME

STATUS

Indiana Bat *Myotis sodalis*

Endangered

Wherever found

There is **final** critical habitat for this species. The location of the critical habitat is not available.

<https://ecos.fws.gov/ecp/species/5949>

Northern Long-eared Bat *Myotis septentrionalis*

Threatened

Wherever found

No critical habitat has been designated for this species.

<https://ecos.fws.gov/ecp/species/9045>

## Critical habitats

Potential effects to critical habitat(s) in this location must be analyzed along with the endangered species themselves.

THERE ARE NO CRITICAL HABITATS AT THIS LOCATION.

## Migratory birds

Certain birds are protected under the Migratory Bird Treaty Act<sup>1</sup> and the Bald and Golden Eagle Protection Act<sup>2</sup>.

Any person or organization who plans or conducts activities that may result in impacts to migratory birds, eagles, and their habitats should follow appropriate regulations and consider implementing appropriate conservation measures, as described [below](#).

1. The [Migratory Birds Treaty Act](#) of 1918.
2. The [Bald and Golden Eagle Protection Act](#) of 1940.

Additional information can be found using the following links:

- Birds of Conservation Concern <http://www.fws.gov/birds/management/managed-species/birds-of-conservation-concern.php>
- Measures for avoiding and minimizing impacts to birds <http://www.fws.gov/birds/management/project-assessment-tools-and-guidance/conservation-measures.php>
- Nationwide conservation measures for birds <http://www.fws.gov/migratorybirds/pdf/management/nationwidestandardconservationmeasures.pdf>

The birds listed below are birds of particular concern either because they occur on the [USFWS Birds of Conservation Concern](#) (BCC) list or warrant special attention in your project location. To learn more about the levels of concern for birds on your list and how this list is generated, see the FAQ [below](#). This is not a list of every bird you may find in this location, nor a guarantee that every bird on this list will be found in your project area. To see exact locations of where birders and the general public have sighted birds in and around your project area, visit the [E-bird data mapping tool](#) (Tip:

enter your location, desired date range and a species on your list). For projects that occur off the Atlantic Coast, additional maps and models detailing the relative occurrence and abundance of bird species on your list are available. Links to additional information about Atlantic Coast birds, and other important information about your migratory bird list, including how to properly interpret and use your migratory bird report, can be found [below](#).

For guidance on when to schedule activities or implement avoidance and minimization measures to reduce impacts to migratory birds on your list, click on the PROBABILITY OF PRESENCE SUMMARY at the top of your list to see when these birds are most likely to be present and breeding in your project area.

NAME

BREEDING SEASON (IF A BREEDING SEASON IS INDICATED FOR A BIRD ON YOUR LIST, THE BIRD MAY BREED IN YOUR PROJECT AREA SOMETIME WITHIN THE TIMEFRAME SPECIFIED, WHICH IS A VERY LIBERAL ESTIMATE OF THE DATES INSIDE WHICH THE BIRD BREEDS ACROSS ITS ENTIRE RANGE. "BREEDS ELSEWHERE" INDICATES THAT THE BIRD DOES NOT LIKELY BREED IN YOUR PROJECT AREA)

**Bald Eagle** *Haliaeetus leucocephalus*

This is not a Bird of Conservation Concern (BCC) in this area, but warrants attention because of the Eagle Act or for potential susceptibilities in offshore areas from certain types of development or activities.

<https://ecos.fws.gov/ecp/species/1626>

Breeds Dec 1 to Aug 31

**Bobolink** *Dolichonyx oryzivorus*

This is a Bird of Conservation Concern (BCC) throughout its range in the continental USA and Alaska.

Breeds May 20 to Jul 31

**Canada Warbler** *Cardellina canadensis*

This is a Bird of Conservation Concern (BCC) throughout its range in the continental USA and Alaska.

Breeds May 20 to Aug 10

**Red-headed Woodpecker** *Melanerpes erythrocephalus*

This is a Bird of Conservation Concern (BCC) throughout its range in the continental USA and Alaska.

Breeds May 10 to Sep 10

**Wood Thrush** *Hylocichla mustelina*

This is a Bird of Conservation Concern (BCC) throughout its range in the continental USA and Alaska.

Breeds May 10 to Aug 31

## Probability of Presence Summary

The graphs below provide our best understanding of when birds of concern are most likely to be present in your project area. This information can be used to tailor and schedule your project activities to avoid or minimize impacts to birds. Please make sure you read and understand the FAQ "Proper Interpretation and Use of Your Migratory Bird Report" before using or attempting to interpret this report.

### Probability of Presence (■)

Each green bar represents the bird's relative probability of presence in the 10km grid cell(s) your project overlaps during a particular week of the year. (A year is represented as 12 4-week months.) A taller bar indicates a higher probability of species presence. The survey effort (see below) can be used to establish a level of confidence in the presence score. One can have higher confidence in the presence score if the corresponding survey effort is also high.

How is the probability of presence score calculated? The calculation is done in three steps:

1. The probability of presence for each week is calculated as the number of survey events in the week where the species was detected divided by the total number of survey events for that week. For example, if in week 12 there were 20 survey events and the Spotted Towhee was found in 5 of them, the probability of presence of the Spotted Towhee in week 12 is 0.25.
2. To properly present the pattern of presence across the year, the relative probability of presence is calculated. This is the probability of presence divided by the maximum probability of presence across all weeks. For example, imagine the probability of presence in week 20 for the Spotted Towhee is 0.05, and that the probability of presence at week 12 (0.25) is the maximum of any week of the year. The relative probability of presence on week 12 is  $0.25/0.25 = 1$ ; at week 20 it is  $0.05/0.25 = 0.2$ .
3. The relative probability of presence calculated in the previous step undergoes a statistical conversion so that all possible values fall between 0 and 10, inclusive. This is the probability of presence score.

To see a bar's probability of presence score, simply hover your mouse cursor over the bar.

### Breeding Season (■)

Yellow bars denote a very liberal estimate of the time-frame inside which the bird breeds across its entire range. If there are no yellow bars shown for a bird, it does not breed in your project area.

### Survey Effort (|)

Vertical black lines superimposed on probability of presence bars indicate the number of surveys performed for that species in the 10km grid cell(s) your project area overlaps. The number of surveys is expressed as a range, for example, 33 to 64 surveys.

To see a bar's survey effort range, simply hover your mouse cursor over the bar.

### No Data (—)

A week is marked as having no data if there were no survey events for that week.

### Survey Timeframe

Surveys from only the last 10 years are used in order to ensure delivery of currently relevant information. The exception to this is areas off the Atlantic coast, where bird returns are based on all years of available data, since data in these areas is currently much more sparse.

■ probability of presence ■ breeding season | survey effort — no data

SPECIES

JAN

FEB

MAR

APR

MAY

JUN

JUL

AUG

SEP

OCT

NOV

DEC

Bald Eagle  
 Non-BCC  
 Vulnerable (This is not a Bird of Conservation Concern (BCC) in this area, but warrants attention because of the Eagle Act or for potential susceptibilities in offshore areas from certain types of development or activities.)

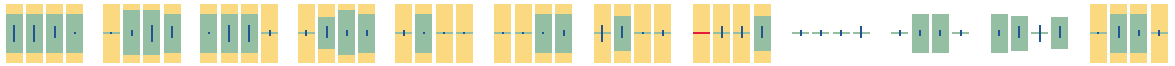

Bobolink  
 BCC Rangewide (CON) (This is a Bird of Conservation Concern (BCC) throughout its range in the continental USA and Alaska.)



Canada Warbler  
 BCC Rangewide (CON) (This is a Bird of Conservation Concern (BCC) throughout its range in the continental USA and Alaska.)



Red-headed Woodpecker  
 BCC Rangewide (CON) (This is a Bird of Conservation Concern (BCC) throughout its range in the continental USA and Alaska.)

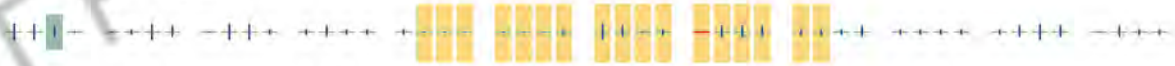

Wood Thrush  
 BCC Rangewide (CON) (This is a Bird of Conservation Concern (BCC) throughout its range in the continental USA and Alaska.)



Tell me more about conservation measures I can implement to avoid or minimize impacts to migratory birds.

[Nationwide Conservation Measures](#) describes measures that can help avoid and minimize impacts to all birds at any location year round. Implementation of these measures is particularly important when birds are most likely to occur in the project area. When birds may be breeding in the area, identifying the locations of any active nests and avoiding their destruction is a very helpful impact minimization measure. To see when birds are most likely to occur and be breeding in your project area, view the Probability of Presence Summary. [Additional measures](#) or [permits](#) may be advisable depending on the type of activity you are conducting and the type of infrastructure or bird species present on your project site.

### **What does IPaC use to generate the migratory birds potentially occurring in my specified location?**

The Migratory Bird Resource List is comprised of USFWS [Birds of Conservation Concern \(BCC\)](#) and other species that may warrant special attention in your project location.

The migratory bird list generated for your project is derived from data provided by the [Avian Knowledge Network \(AKN\)](#). The AKN data is based on a growing collection of [survey, banding, and citizen science datasets](#) and is queried and filtered to return a list of those birds reported as occurring in the 10km grid cell(s) which your project intersects, and that have been identified as warranting special attention because they are a BCC species in that area, an eagle ([Eagle Act](#) requirements may apply), or a species that has a particular vulnerability to offshore activities or development.

Again, the Migratory Bird Resource list includes only a subset of birds that may occur in your project area. It is not representative of all birds that may occur in your project area. To get a list of all birds potentially present in your project area, please visit the [AKN Phenology Tool](#).

### **What does IPaC use to generate the probability of presence graphs for the migratory birds potentially occurring in my specified location?**

The probability of presence graphs associated with your migratory bird list are based on data provided by the [Avian Knowledge Network \(AKN\)](#). This data is derived from a growing collection of [survey, banding, and citizen science datasets](#).

Probability of presence data is continuously being updated as new and better information becomes available. To learn more about how the probability of presence graphs are produced and how to interpret them, go the Probability of Presence Summary and then click on the "Tell me about these graphs" link.

### **How do I know if a bird is breeding, wintering, migrating or present year-round in my project area?**

To see what part of a particular bird's range your project area falls within (i.e. breeding, wintering, migrating or year-round), you may refer to the following resources: [The Cornell Lab of Ornithology All About Birds Bird Guide](#), or (if you are unsuccessful in locating the bird of interest there), the [Cornell Lab of Ornithology Neotropical Birds guide](#). If a bird on your migratory bird species list has a breeding season associated with it, if that bird does occur in your project area, there may be nests present at some point within the timeframe specified. If "Breeds elsewhere" is indicated, then the bird likely does not breed in your project area.

### **What are the levels of concern for migratory birds?**

Migratory birds delivered through IPaC fall into the following distinct categories of concern:

1. "BCC Rangelwide" birds are [Birds of Conservation Concern \(BCC\)](#) that are of concern throughout their range anywhere within the USA (including Hawaii, the Pacific Islands, Puerto Rico, and the Virgin Islands);
2. "BCC - BCR" birds are BCCs that are of concern only in particular Bird Conservation Regions (BCRs) in the continental USA; and
3. "Non-BCC - Vulnerable" birds are not BCC species in your project area, but appear on your list either because of the [Eagle Act](#) requirements (for eagles) or (for non-eagles) potential susceptibilities in offshore areas from certain types of development or activities (e.g. offshore energy development or longline fishing).

Although it is important to try to avoid and minimize impacts to all birds, efforts should be made, in particular, to avoid and minimize impacts to the birds on this list, especially eagles and BCC species of rangewide concern. For more information on conservation measures you can implement to help avoid and minimize migratory bird impacts and requirements for eagles, please see the FAQs for these topics.

### Details about birds that are potentially affected by offshore projects

For additional details about the relative occurrence and abundance of both individual bird species and groups of bird species within your project area off the Atlantic Coast, please visit the [Northeast Ocean Data Portal](#). The Portal also offers data and information about other taxa besides birds that may be helpful to you in your project review. Alternately, you may download the bird model results files underlying the portal maps through the [NOAA NCCOS Integrative Statistical Modeling and Predictive Mapping of Marine Bird Distributions and Abundance on the Atlantic Outer Continental Shelf](#) project webpage.

Bird tracking data can also provide additional details about occurrence and habitat use throughout the year, including migration. Models relying on survey data may not include this information. For additional information on marine bird tracking data, see the [Diving Bird Study](#) and the [nanotag studies](#) or contact [Caleb Spiegel](#) or [Pam Loring](#).

### What if I have eagles on my list?

If your project has the potential to disturb or kill eagles, you may need to [obtain a permit](#) to avoid violating the Eagle Act should such impacts occur.

### Proper Interpretation and Use of Your Migratory Bird Report

The migratory bird list generated is not a list of all birds in your project area, only a subset of birds of priority concern. To learn more about how your list is generated, and see options for identifying what other birds may be in your project area, please see the FAQ "What does IPaC use to generate the migratory birds potentially occurring in my specified location". Please be aware this report provides the "probability of presence" of birds within the 10 km grid cell(s) that overlap your project; not your exact project footprint. On the graphs provided, please also look carefully at the survey effort (indicated by the black vertical bar) and for the existence of the "no data" indicator (a red horizontal bar). A high survey effort is the key component. If the survey effort is high, then the probability of presence score can be viewed as more dependable. In contrast, a low survey effort bar or no data bar means a lack of data and, therefore, a lack of certainty about presence of the species. This list is not perfect; it is simply a starting point for identifying what birds of concern have the potential to be in your project area, when they might be there, and if they might be breeding (which means nests might be present). The list helps you know what to look for to confirm presence, and helps guide you in knowing when to implement conservation measures to avoid or minimize potential impacts from your project activities, should presence be confirmed. To learn more about conservation measures, visit the FAQ "Tell me about conservation measures I can implement to avoid or minimize impacts to migratory birds" at the bottom of your migratory bird trust resources page.

## Facilities

### National Wildlife Refuge lands

Any activity proposed on lands managed by the [National Wildlife Refuge](#) system must undergo a 'Compatibility Determination' conducted by the Refuge. Please contact the individual Refuges to discuss any questions or concerns.

THERE ARE NO REFUGE LANDS AT THIS LOCATION.

## Fish hatcheries

THERE ARE NO FISH HATCHERIES AT THIS LOCATION.

## Wetlands in the National Wetlands Inventory

Impacts to [NWI wetlands](#) and other aquatic habitats may be subject to regulation under Section 404 of the Clean Water Act, or other State/Federal statutes.

For more information please contact the Regulatory Program of the local [U.S. Army Corps of Engineers District](#).

THERE ARE NO KNOWN WETLANDS AT THIS LOCATION.

### Data limitations

The Service's objective of mapping wetlands and deepwater habitats is to produce reconnaissance level information on the location, type and size of these resources. The maps are prepared from the analysis of high altitude imagery. Wetlands are identified based on vegetation, visible hydrology and geography. A margin of error is inherent in the use of imagery; thus, detailed on-the-ground inspection of any particular site may result in revision of the wetland boundaries or classification established through image analysis.

The accuracy of image interpretation depends on the quality of the imagery, the experience of the image analysts, the amount and quality of the collateral data and the amount of ground truth verification work conducted. Metadata should be consulted to determine the date of the source imagery used and any mapping problems.

Wetlands or other mapped features may have changed since the date of the imagery or field work. There may be occasional differences in polygon boundaries or classifications between the information depicted on the map and the actual conditions on site.

### Data exclusions

Certain wetland habitats are excluded from the National mapping program because of the limitations of aerial imagery as the primary data source used to detect wetlands. These habitats include seagrasses or submerged aquatic vegetation that are found in the intertidal and subtidal zones of estuaries and nearshore coastal waters. Some deepwater reef communities (coral or tubercid worm reefs) have also been excluded from the inventory. These habitats, because of their depth, go undetected by aerial imagery.

### Data precautions

Federal, state, and local regulatory agencies with jurisdiction over wetlands may define and describe wetlands in a different manner than that used in this inventory. There is no attempt, in either the design or products of this inventory, to define the limits of proprietary jurisdiction of any Federal, state, or local government or to establish the geographical scope of the regulatory programs of government agencies. Persons intending to engage in activities involving modifications within or adjacent to wetland areas should seek the advice of appropriate

federal, state, or local agencies concerning specified agency regulatory programs and proprietary jurisdictions that may affect such activities.

NOT FOR CONSULTATION

**ATTACHMENT C**  
**NYSDEC Information**

---



**NEW YORK STATE DEPARTMENT OF ENVIRONMENTAL CONSERVATION**

Division of Environmental Permits, Region 3  
21 South Putt Corners Road, New Paltz, NY 12561-1620  
P: (845) 256-3054 | F: (845) 255-4659  
www.dec.ny.gov



**Department of  
Environmental  
Conservation**

February 5, 2020

Barbara Roberti, Zoning Administrator  
Town of Wappinger Planning Board  
20 Middlebush Road  
Wappinger, New York 12590

RE: Gasland Petroleum Route 9D (Hughsonville) – 2361 Route 9D  
Tax ID#s 135689-6157-01-048643; 135689-6157-01-057642; 135689-6157-01-057654; and 135689-6157-01-059643  
Town of Wappinger, Dutchess County  
CH# 8627  
**SEQR Lead Agency Designation**

Dear Ms. Roberti:

The New York State Department of Environmental Conservation (Department or DEC) has reviewed the State Environmental Quality Review (SEQR) Notice of Intent to Serve as Lead Agency submitted by the Town of Wappinger Planning Board for the above-referenced project. According to the submitted information, the applicant proposes to develop a gasoline-filling station comprised of four pumps with eight fueling stations. A 2,700-square foot (SF) convenience store with two one-bedroom apartments located above is also proposed. A 21-space parking area (including four spaces at the proposed fueling stations) is proposed to serve the facility. The project site is currently comprised of four individual parcels (referenced above); this proposal includes the consolidation of these parcels into a single lot.

The DEC has no objection to the Town of Wappinger Planning Board serving as lead agency for this project. Based upon our review of your inquiry received by this office on January 17, 2020, the Department offers the following comments:

**WATER QUALITY CERTIFICATION**

The project site does not appear to contain a federally-regulated wetland area. If the United States Army Corps of Engineers (ACOE) requires a permit for work completed in or impacting a federal wetland, you will need a Section 401 Water Quality Certification from the Department. Please contact the ACOE at (917) 790-8411 for a determination.



### **STATE-LISTED SPECIES**

The DEC has reviewed the State's Natural Heritage records. We have determined that the site is located within or near records of the following state-listed species:

<u>Name</u>	<u>Status</u>
Bald eagle ( <i>Haliaeetus leucocephalus</i> )	Threatened
Indiana bat ( <i>Myotis sodalis</i> )	Endangered

Any potential impacts of the proposed project on these species should be fully evaluated during the review of the project pursuant to SEQR. A permit is required for the incidental taking of any species identified as "endangered" or "threatened," which can include the removal of habitat. In addition, project modifications may be needed to avoid or adequately mitigate any potential impacts identified.

#### **Bald eagle:**

Based on the location of the project relative to the nearest documented bald eagle nest, the Department has determined that this project is not likely to impact this species. No further review is necessary for this species at this time.

However, please note that information on eagle nest locations represents our current knowledge of these resources. New eagle nests could be documented with each breeding season and would, at that point, need to be addressed as well. It is best to check in each year to see if any new nests have been established.

#### **Indiana bat:**

To avoid adverse impacts to Indiana bats and the need for an Incidental Take Permit pursuant to 6 NYCRR Part 182, all tree removal must take place from October 1st through March 31st. If the project sponsor cannot complete tree clearing within this time of year restriction, then the Department will require further review on the impacts to this species. Additional project modifications may be needed to avoid or adequately mitigate any potential impacts identified.

Please note that a project sponsor may not commence site preparation, including tree clearing, until the provisions of SEQR are complied with and all necessary permits are issued for the proposed project.

For technical questions regarding these species and their associated avoidance and mitigation measures, please contact the NYSDEC Bureau of Wildlife at (845) 256-3098.

The absence of data does not necessarily mean that other rare or state-listed species, natural communities, or other significant habitats do not exist on or adjacent to the proposed site. Rather, our files currently do not contain information which indicates their presence. For most sites, comprehensive field surveys have not been conducted. We cannot provide a definitive statement on the presence or absence of all rare or state-listed species or significant natural communities. Depending on the nature of the project and the conditions at the project site, further information from on-site surveys or other sources may be required to fully assess impacts on biological resources.

### **STATE POLLUTION DISCHARGE ELIMINATION SYSTEM (SPDES)**

Since project activities will disturb over one acre of land, the project sponsor must obtain coverage under the current SPDES General Permit for Stormwater Discharge from Construction Activity (GP-0-20-001) and develop a Stormwater Pollution Prevention Plan (SWPPP) that conforms to requirements of the General Permit.

As this site is within a Municipal Separate Storm Sewer System (MS4) community, the municipality is responsible for review and acceptance of the SWPPP, and the MS-4 Acceptance Form must be submitted to the Department. For information on stormwater and the general permits, see the DEC website at <http://www.dec.ny.gov/chemical/8468.html>.

According to the project narrative, the proposed convenience store will be served by a new on-site septic disposal system. The narrative states that if the two proposed one-bedroom apartments cannot be connected to this septic disposal system, they will be connected to a holding tank on a temporary basis until municipal service is brought to the area.

The Full Environmental Assessment Form (EAF) states that the proposed project is expected to generate approximately 544 gallons per day (gpd) of sanitary wastewater. Please note, sewage effluent discharges of 1,000 gpd or greater to groundwater are regulated under Article 17, Titles 7 and 8 of the Environmental Conservation Law (ECL) and require a SPDES permit. For additional information on SPDES permits, please visit the DEC website at <http://www.dec.ny.gov/permits/6054.html>.

### **WATER WITHDRAWAL**

According to the EAF, the proposed project site will generate a demand for water of approximately 544 gpd, which will be served by the existing United Wappinger Water District. A service line extension from New Hamburg Road is proposed to serve the project. Please note that additional Department approval may be required to ensure that the site is covered under an existing Water Withdrawal permit and does not exceed the authorized maximum taking of water into the existing water district or service area. For more information, please contact DEC Division of Water at (914) 428-2505.

### **CULTURAL RESOURCES**

We have reviewed the statewide inventory of archaeological resources maintained by the New York State Museum and the New York State Office of Parks, Recreation, and Historic Preservation. These records indicate that the project is located within an area considered to be sensitive with regard to archaeological resources. The project sponsor should submit project materials to the New York State Historic Preservation Office's online Cultural Resource Information System (CRIS) to initiate the review process. Information on submitting to the system and access to it are available at <http://www.nysparks.com/shpo/>.

### **PETROLEUM BULK STORAGE (PBS) PROGRAM**

The EAF indicates that the proposed project will include bulk storage of gasoline and diesel fuel. The petroleum products are to be stored in two 12,000-gallon double-wall fiberglass underground storage tanks with associated piping. The PBS Program applies to properties which have, except for tank systems that are specifically exempted:

- One or more tank systems that are designed to store a combined capacity of 1,100 or more gallons of petroleum in aboveground and/or underground storage tanks; or
- One or more underground tank systems that are designed to store 110 or more gallons of petroleum.

As the proposal exceeds the above criteria, it will be considered a "facility" and all tank systems storing petroleum must be registered with the Department and managed in compliance with applicable regulations for the storage of petroleum. In addition, per 6 NYCRR Subpart 374-2 Standards for the Management of Used Oil, all aboveground and underground tank systems designed to store used oil, regardless of size, must be registered with the Department and managed with applicable regulations for storage and handling of petroleum. For more information about the PBS Program and how to apply, please visit our website at <https://www.dec.ny.gov/chemical/287.html>.

### **COASTAL MANAGEMENT ZONE**

The project site is located within the Coastal Management Zone. If the Department has individual permit approvals for this project, the Department would review it in accordance with Coastal Management Program requirements. For additional information about the Coastal Management Zone, please contact the NYS Department of State (DOS), (518) 474-6000.

### **OTHER**

Other permits from this Department or other agencies may be required for projects conducted on this property now or in the future. Also, regulations applicable to the location subject to this determination occasionally are revised and the project sponsor should, therefore, verify the need for permits if your project is delayed or postponed. This determination regarding the need for permits will remain effective for a maximum of one year. More information about DEC permits may be found on our website, [www.dec.ny.gov](http://www.dec.ny.gov), under "Regulatory" then "Permits and Licenses." Application forms may be downloaded at <http://www.dec.ny.gov/permits/6081.html>.

Please contact this office if you have questions regarding the above information. Thank you.

Sincerely,



Christina Pacella  
Division of Environmental Permits  
Region 3, Telephone No. (845) 256-2250

RE: Gasland Petroleum Route 9D (Hughsonville) – 2361 Route 9D  
Town of Wappinger, Dutchess County  
CH# 8627  
SEQR Lead Agency Designation

February 5, 2020

Enc: Indiana Bat Project Review Fact Sheet

cc: Lisa Masi, NYSDEC Bureau of Wildlife  
Josh Cummins, NYSDEC Bulk Storage Program  
Aparna Roy, NYSDEC Division of Water  
NYSDOS Office of Planning & Development  
Gas Land Petroleum, Inc., Applicant

## Indiana Bat Project Review Fact Sheet

### New York Field Office

The following fact sheet is intended to provide information to assist project sponsors, as well as any involved Federal and State agencies, with the review of activities that occur within the likely range of the Indiana bat (*Myotis sodalis*) within the State of New York. This fact sheet can be used to assist with compliance with the Endangered Species Act (ESA) (87 Stat. 884, as amended; 16 U.S.C. 1531 *et seq.*). **PLEASE NOTE - this fact sheet does not apply to wind development projects as they involve many unique considerations.** Contact the U.S. Fish and Wildlife Service (Service) directly for technical assistance for wind projects. In addition, information on evaluating impacts from wind projects on Indiana bats can be found at <http://www.fws.gov/midwest/endangered/mammals/inba/WindEnergyGuidance.html>.

### *Background*

The Indiana bat is federally- and New York State-listed as an endangered species with a range that extends from the Midwest to northeastern and southeastern parts of the United States. Additional information on Indiana bat occurrences can be found at <http://ecos.fws.gov> and <https://www.fws.gov/northeast/nyfo/es/NYSpecies.htm>.

The Indiana bat typically hibernates in caves/mines in the winter and roosts under bark or in tree crevices in the spring, summer, and fall. Suitable potential summer roosting habitat is characterized by trees (dead, dying, or alive) or snags with exfoliating bark, or containing cracks or crevices that could potentially be used by Indiana bats as a roost. The minimum size roost tree observed to date is 2.5 inches diameter breast height (d.b.h.) for males and 4.3 inches d.b.h. for females. However, maternity colonies generally use trees greater than or equal to 9 inches d.b.h. Overall, roost tree structure appears to be more important to Indiana bats than a particular tree species or habitat type. Females appear to be more habitat specific than males presumably because of the warmer temperature requirements associated with gestation and rearing of young. As a result, they are generally found at lower elevations than males may be found. Roosts are warmed by direct exposure to solar radiation, thus trees exposed to extended periods of direct sunlight are preferred over those in shaded areas. However, shaded roosts may be preferred in very hot conditions. As larger trees afford a greater thermal mass for heat retention, they appear to be preferred over smaller trees. Additional information on potentially suitable summer habitat can be found in the Draft Indiana Bat Recovery Plan (Service 2007) at <http://www.fws.gov/northeast/nyfo/es/IndianaBatapr07.pdf> and at <http://www.fws.gov/midwest/endangered/mammals/inba/inbasummersurveyguidance.html>

Streams associated with floodplain forests, and impounded water bodies (ponds, wetlands, reservoirs, etc.) where abundant supplies of flying insects are likely found, provide preferred foraging habitat for Indiana bats, some of which may fly up to 2-5 miles from upland roosts on a regular basis. Indiana bats also forage within the canopy of upland forests, over clearings with early successional vegetation (*e.g.*, old fields), along the borders of croplands, along wooded fencerows, and over farm ponds in pastures (Service 2007). While Indiana bats appear to forage in a wide variety of habitats, they seem to tend to stay fairly close to tree cover.

Threats include disease (white-nose syndrome), habitat loss or degradation, human disturbance, contaminants, and collision with wind turbines.

**Indiana Bat Project Review Fact Sheet**  
New York Field Office

*Evaluation of Presence or Probable Absence*

To determine whether the proposed project site may be occupied by the Indiana bat, the Service recommends the following analytical approach<sup>1</sup>:

Step 1. Is the proposed project within an area<sup>2</sup> identified by the Service as known or likely to contain Indiana bats?

- No: No further coordination regarding the Indiana bat is necessary at this time.
- Yes: Proceed to Step 2.

Step 2. Is there existing information regarding probable presence/absence of Indiana bats (*e.g.*, proximity to hibernacula, prior summer netting/acoustics)<sup>3</sup>?

- No: Proceed to Step 3.
- Yes: Document existing information and coordinate with the Service.

Step 3. Is there any suitable Indiana bat habitat<sup>4</sup> present within the proposed action project area?

- No: No further coordination regarding the Indiana bat is necessary at this time.
- Yes: Determine whether the proposed project involves any effects to Indiana bats.

*Determination of Effects*

Determine for each project whether effects to Indiana bats or their habitat are expected. If there are impacts to habitat while bats are not present, assess the scale and scope of those impacts to determine whether bats returning in the spring may be affected.

For example, consider whether a project may result in temporary or permanent increases in noise, vibration, dust, chemical use, lighting, vehicle use, and general levels of human activity. Also, consider whether a project may result in temporary or permanent loss, degradation, and/or fragmentation of roosting, foraging, swarming, commuting, or wintering habitat.

Certain transportation projects have already been evaluated and processes developed in accordance with a Rangewide Consultation and Conservation Strategy:

<https://www.fws.gov/Midwest/Endangered/section7/fhwa/>

*Surveys for Indiana Bats*

Should suitable Indiana bat habitat be present and should the proposed project have the potential for impacting Indiana bats, coordinate with the Service to determine whether 1) assuming presence or 2) conducting surveys<sup>5</sup> is the best approach. Due to the limited time frame when bat surveys can be completed and in order to avoid project delays, it is strongly recommended that the project sponsor (or involved Federal agency) contact the Service as early as possible during

---

<sup>1</sup> This reflects our current understanding but future studies may require a revision to this guidance.

<sup>2</sup> <https://ecos.fws.gov/ipac/>

<sup>3</sup> <http://www.fws.gov/northeast/nyfo/es/NYSpecies.htm> and <http://www.dec.ny.gov/animals/38801.html>

<sup>4</sup> <http://www.fws.gov/midwest/Endangered/mammals/inba/inbasummersurveyguidance.html>

<sup>5</sup> <http://www.fws.gov/midwest/Endangered/mammals/inba/inbasummersurveyguidance.html>

## Indiana Bat Project Review Fact Sheet

### New York Field Office

project planning to determine if surveys or additional avoidance and/or minimization measures are appropriate. Should Indiana bat presence be detected, the Service should be contacted immediately for further assistance in determining whether your action may impact Indiana bats. If no bats are detected after protocol surveys, submit the results as soon as possible for our review in accordance with the timeframes agreed upon during the review of the survey scope of work.

### *Conservation Measures*

Conservation measures are designed to minimize the likelihood of adverse impacts or result in beneficial effects to Indiana bats from projects. The following guidance represents general recommendations that may be incorporated into the proposed project design as appropriate.

### Project Siting

- Avoid removing or damaging documented roosts or trees surrounding roosts.
- Avoid impacts to forest patches with documented roosts/foraging use (*e.g.*, forest within 0.25 mile of known roosts).
- Minimize impacts to all forest patches.
- Maintain forest patches and forested connections (*e.g.*, hedgerows, riparian corridors) between patches.
- Maintain natural vegetation between forest patches/connections and developed areas.
- Maintain at least 35%<sup>6</sup> of forest habitat within maternity colony home range<sup>7</sup>.
- Restore and/or protect on- and off-site habitat.
- Avoid impacting potential roost trees to the greatest extent practicable
  - Retain standing live trees that have exfoliating (separated from cambium) bark.
  - Retain black locust, shellbark, shagbark, and bitternut hickories as possible, regardless of size or condition (live, dead, or dying).
  - Retain standing snags as much as possible regardless of species.

### Project Construction

- When >10 miles from a P3 or P4 hibernaculum or >20 miles from a P1 or P2 hibernaculum<sup>8</sup>, but within the summer range of the Indiana bat, the clearing of potential roost trees, generally  $\geq 4$  inches should occur from October 1 through March 31<sup>9</sup>.
- When <10 miles from a P3 or P4 hibernaculum or <20 miles from a P1 or P2 hibernaculum, clearing should be conducted from October 31 to March 31.
- Use bright flagging/fencing to demarcate trees to be cleared.

---

<sup>6</sup> Minimum % forest cover within Indiana bat maternity colony home range (NYSDEC unpublished data)

<sup>7</sup> For explanation of how to delineate Indiana bat maternity colony home range, please see the Indiana Bat Section 7 and Section 10 Guidance for Wind Energy Projects document located at <http://www.fws.gov/midwest/Endangered/mammals/inba/index.html>

<sup>8</sup> See Service 2007 for definitions of Priority 1-4 hibernacula. Contact the NYFO for information regarding the closest hibernaculum to your project

<sup>9</sup> Site specific information may allow for deviations from the listed dates. Also, there may be cases (*e.g.*, very small number of trees) when we believe the likelihood of impacts is low regardless of when tree removal occurs.

**Indiana Bat Project Review Fact Sheet**  
New York Field Office

Project Operations/Maintenance

- Minimize lighting impacts (e.g., limit number of lights, direct lights downward, fully shield lights, use motion sensors or timers).
- Conduct activities in a manner that will minimize impacts to potential drinking water sources for bats.

As we better understand a given proposed project, including any proposed conservation measures for Indiana bats, we may have additional recommendations. Project sponsors should seek assistance from the Service to develop these measures.

*Information to Provide to the Service*

The project's environmental documents should identify project activities that might result in impacts to the Indiana bat or their habitat. Information on any potential impacts and the results of any recommended habitat analyses or surveys for the Indiana bat should be provided to the New York Field Office and will be used to evaluate potential impacts to the Indiana bat and/or their habitat, and to determine the need for further coordination or consultation pursuant to the ESA. We encourage the project sponsor to submit these materials as early in the planning process as possible to all appropriate parties (e.g., involved Federal/State agencies, the New York State Department of Environmental Conservation, Service).

Specifically, the following information should be provided:

- whether a Federal agency is involved or not;
- a detailed project description;
- a map of the proposed project area with coarse vegetation cover types (e.g., emergent wetland, open field) in acres;
- a summary table of current vs. proposed future acreage of each cover type;
- provide number or acreage of trees proposed for removal and timing of removal;
- an overlay of the project on the vegetation map;
- a description of the forested area onsite, including the type of forest (e.g., oak-hickory), approximate stand age, and presence of dead or live trees with split branches or trunks or exfoliating bark;
- photographs representative of all cover types on the site and encompassing views of the entire site;
- a topographic map with the project area identified; and
- a summary of proposed conservation measures.

References:

U.S. Fish and Wildlife Service. 2007. Indiana Bat (*Myotis sodalis*) Draft Recovery Plan: First Revision. U.S. Fish and Wildlife Service, Fort Snelling, MN. 258 pp.



**ATTACHMENT D**  
**NYSOPRHP Information**

---





**Parks, Recreation,  
and Historic Preservation**

**ANDREW M. CUOMO**  
Governor

**ERIK KULLESEID**  
Commissioner

April 14, 2020

Caren LoBrutto  
Senior Planner  
Chazen Companies  
21 Fox Street  
Poughkeepsie, NY 12601

Re: DEC  
Gas Land Petroleum - Route 9D  
2361 Route 9D, Town of Wappinger, Dutchess County, NY  
20PR01993

Dear Caren LoBrutto:

Thank you for requesting the comments of the Office of Parks, Recreation and Historic Preservation (OPRHP). We have reviewed the project in accordance with the New York State Historic Preservation Act of 1980 (Section 14.09 of the New York Parks, Recreation and Historic Preservation Law). These comments are those of the OPRHP and relate only to Historic/Cultural resources. They do not include potential environmental impacts to New York State Parkland that may be involved in or near your project. Such impacts must be considered as part of the environmental review of the project pursuant to the State Environmental Quality Review Act (New York Environmental Conservation Law Article 8) and its implementing regulations (6 NYCRR Part 617).

Based upon this review, it is the opinion of OPRHP that no properties, including archaeological and/or historic resources, listed in or eligible for the New York State and National Registers of Historic Places will be impacted by this project.

If further correspondence is required regarding this project, please be sure to refer to the OPRHP Project Review (PR) number noted above.

Sincerely,

R. Daniel Mackay

Deputy Commissioner for Historic Preservation  
Division for Historic Preservation



ATTACHMENT E  
Typical Underground Petroleum  
Storage Tank Drawing

---



**SHORT FORM SPECIFICATION**

The contractor shall provide the appropriate double or triple-wall fiberglass storage tank and accessories as indicated on tank drawings. Capacity, dimensions and fitting locations will be indicated on tank drawings. Tanks shall be manufactured by Containment Solutions, Inc. The tank must be tested and installed according to manufacturer's current installation instructions.

**LONG FORM SPECIFICATION****1. GENERAL**

## 1.1. Quality Assurance

## 1.1.1. Acceptable Manufacturers:

Containment Solutions, Inc., Conroe, Texas

## 1.1.2. Governing Standards, as applicable:

1.1.2.1. Underwriters Laboratories Inc. Standard 1316, Glass-Fiber Reinforced Plastic Underground Storage Tanks for Petroleum Products, Alcohols, and Alcohol-Gasoline Mixtures.

1.1.2.2. Underwriters Laboratories of Canada standard ULC-S615, Reinforced Plastic Underground Tanks for Flammable & Combustible Liquids.

1.1.2.3. National Fire Protection Association codes and standards:

- NFPA 30 Flammable and Combustible Liquids Code
- NFPA 30A Motor Fuel Dispensing Facilities and Repair Garages Code
- NFPA 31 Installation of Oil-Burning Equipment Standard

1.1.2.4. City of New York Department of Buildings M.E.A., 71-85-M

1.1.2.5. American Concrete Institute standard ACI 318, Building Code Requirements for Structural Concrete.

## 1.2. Submittals

1.2.1. Contractor shall submit \_\_\_\_ copies of: shop drawings, manufacturer's product brochures, installation instructions and calibration charts.

**2. PRODUCTS**

## 2.1. Double-Wall and Triple-Wall

Fiberglass Underground Storage Tanks

## 2.1.1. Loading Conditions - Tanks shall meet the following design criteria:

2.1.1.1. External hydrostatic pressure: Buried in ground with 7' of over burden over the top of the tank, the excavation fully flooded and a safety factor of 5:1 against general buckling.

2.1.1.2. Surface Loads: When installed according to manufacturer's current installation instructions, tanks shall withstand surface HS-20 axle loads (32,000 lbs/axle).

2.1.1.3. Internal Load: Primary and secondary tanks shall withstand 5 psig (35kPa), or 3 psig for 12' diameter tanks, air pressure test with 5:1 safety factor.

2.1.1.4. Tanks shall be designed to support accessory equipment such as heating coils, ladders, drop tubes, etc. when installed according to manufacturer's recommendations and limitations.

## 2.1.2. Product-Storage Requirements

2.1.2.1. All primary tanks must be vented. Tanks are designed for operation at atmospheric pressure only, except for use with vapor recovery systems at a pressure or vacuum not to exceed 1 psig (7 kPa).

2.1.2.2. Tanks shall be capable of storing liquids with specific gravity up to 1.1.

2.1.2.3. Tank shall be capable of storing the following products:

- Diesel fuel oils for oil burning equipment at temperatures not to exceed 150°F.
- Gasoline, jet fuel, aviation gasoline, motor oil (new or used), kerosene, diesel motor fuel at ambient temperatures.
- Alcohol-gasoline blend motor fuels at ambient temperatures:
  - Gasoline-ethanol blends with up to 100% ethanol.
  - Gasoline-methanol blends with up to 100% methanol.
- Oxygenated motor fuels at ambient temperatures with up to 20% (by volume) methyl tertiary butyl ether (MTBE), ethyl tertiary butyl ether (ETBE), di-isopropyl ether (DIPE), tertiary butyl alcohol (TBA), tertiary amyl methyl ether (TAME), or tertiary amyl ethyl ether (TAEE).
- Biodiesel-diesel blends with up to 100% biodiesel (B100 per ASTM) at ambient temperatures.

### 2.1.3. Materials

- 2.1.3.1. The tank shall be manufactured as a matrix of premium resin, glass fibers and silane-treated silica that together result in a composite providing improved corrosion protection.
- 2.1.3.2. Tank inner wall shall be fabricated against a mold to produce a non-air inhibited and high gloss laminate to provide a fully cured inner surface without the need for wax coats, a low coefficient of friction and a natural resistance to the build-up of algae or other contamination on the surface. Wax and wax resin coatings cannot be used to achieve full surface cure on tank shells and endcaps.

### 2.1.4. Dimensional Requirements (refer to Containment Solutions literature)

- 2.1.4.1. Nominal capacity of the tank shall be \_\_\_\_ gallons / liters.
- 2.1.4.2. Nominal outside diameter of the tank shall be \_\_\_\_ feet.
- 2.1.4.3. Nominal overall length of the tank shall be \_\_\_\_ feet.

### 2.1.5. Monitoring Capabilities

- 2.1.5.1. Double and triple-wall tanks shall have a monitoring space between the walls to allow for the free flow and containment of leaked product from the primary tank. The monitoring space shall provide equal communication in all directions.
- 2.1.5.2. The following continuous monitoring conditions shall be compatible with the cavity between the inner and outer tanks:
  - Vented to atmosphere
  - Vacuum – 5 psig maximum
  - Positive air pressure (3 psig maximum)
  - External hydrostatic pressure – 7' maximum groundwater head pressure over tank top
- 2.1.5.3. Tanks 6' diameter and larger shall have an integrally mounted annular space reservoir installed on the tank for factory-installed brine and continuous hydrostatic monitoring. The reservoir shall be constructed of fiberglass reinforced plastic materials and be included in the tank warranty.
- 2.1.5.4. The monitoring fitting for the monitoring space shall be a 4" NPT fitting.
- 2.1.5.5. The monitoring system shall be capable of detecting a breach in the inner and outer tank under the following installed conditions:
  - When the primary tank is empty.
  - When the primary tank is partially or completely full and the ground water table is below tank bottom.
  - When the primary tank is partially or completely full and the tank is partially or completely submerged in groundwater.
- 2.1.5.6. The leak detection performance of the monitoring system shall be listed as a continuous interstitial monitoring method (liquid filled) by the National Work Group on Leak Detection Evaluations (NWGLDE). The system should be capable of detecting leaks in the primary or secondary tank walls as small as 0.10 gallons per hour within one-month.
- 2.1.5.7. The hydrostatic monitoring system shall be capable of a precision tank test that is listed by the National Work Group on Leak Detection Evaluations (NWGLDE).
- 2.1.5.8. If hydrostatically monitored, any solution used in the monitoring space shall be compatible with the tank and be of a contrasting color to the tank.

## 2.2. Accessories

### 2.2.1. Flanged Manways

- 2.2.1.1. The standard manway is 22" I.D. and will be furnished with UL listed gaskets and covers (30" and 36" manways are optional).
- 2.2.1.2. Location – see standard tank drawings.
- 2.2.1.3. Optional manway extensions shall be fiberglass and \_\_\_\_ feet long.

### 2.2.2. Fill Tubes - Fill tubes of appropriate design shall be supplied by contractor.

### 2.2.3. Hydrostatic Monitor Accessories

- 2.2.3.1. Brine monitoring fluid shall be a calcium chloride solution.
- 2.2.3.2. Double float reservoir sensor supplied by contractor shall be designed for CSI reservoirs. The components of the sensor shall be compatible with brine and provide two alarm points positioned 10" apart.

### 2.2.4. Secondary Containment Collar

- 2.2.4.1. UL label shall be affixed to collar.
- 2.2.4.2. The collar shall be fiberglass reinforced plastic, 42" or 48" in diameter and shall be factory-installed in accordance with drawings.
- 2.2.4.3. The collar shall include an internal adhesive channel.
- 2.2.4.4. The collar shall be included in the 30-year tank warranty.

### 2.2.5. Adhesive Kit (Kit AD)

- 2.2.5.1. UL Listed and alcohol compatible adhesive kit shall provide a watertight seal at the tank sump and containment collar joint to prevent the ingress of water or egress of fuel. The adhesive kit includes resin, catalyst, mixing stick, putty knife, sandpaper, grout bag, and installation instructions.

## 2.2.6. Tank Sumps

- 2.2.6.1. UL label shall be affixed to tank sump components.
- 2.2.6.2. Tank sumps & collars shall be listed by Underwriters Laboratories for petroleum fuels and all blends of alcohol (same as tank). Collar and sump shall be tested and listed as a complete sump system.
- 2.2.6.3. Tank sump components shall be constructed of fiberglass reinforced plastic. The tank sump shall be 42" or 48" in diameter and must mount to the secondary containment collar. Standard tank sump shall consist of an octagon shaped base (round base is optional), round body extension and enclosure top.
- 2.2.6.4. The octagon base shall be 24" in height and provide 19" high panels for piping entry points. The base must be capable of joining to the collar with an internal adhesive channel.
- 2.2.6.5. A 34" O.D. watertight lid shall be provided at the submersible and fill/vapor end of the tank and provide a watertight seal to the sump enclosure with 12" of water above the lid and remain leak free.
- 2.2.6.6. Refer to tank sump drawings for standard models and configurations.

## 2.2.7. Ladders

- 2.2.7.1. Ladders shall be supplied by the tank manufacturer (carbon steel, stainless steel, aluminum).

## 2.2.8. Anchor Straps

- 2.2.8.1. Straps shall be supplied by the tank manufacturer.
- 2.2.8.2. Number and location of straps shall be as specified by manufacturer.
- 2.2.8.3. Each strap shall be capable of withstanding a maximum load of 25,000 lbs.

## 2.2.9. Prefabricated Concrete Deadmen Anchors

- 2.2.9.1. Design Conditions – Deadmen shall meet the following design criteria:
  - Deadman shall be designed to ACI 318
  - Manufactured with 4,000 psig concrete
  - Manufactured in various lengths
  - Provide adjustable anchor points for hold down straps

## 2.2.10. Liquid Sensor Drawstring

- 2.2.10.1. Galvanized steel drawstring shall be factory installed at the monitoring fitting to facilitate field insertion of sensor.

## 2.2.11. Fittings Threaded NPT

- 2.2.11.1. All threaded fittings shall be located on a manway cover or within 12" of the tank top center line. Fittings to be supplied with temporary thread protectors or threaded plugs.
- 2.2.11.2. All standard fittings shall be 4" diameter NPT half couplings.
- 2.2.11.3. Internal piping shall be terminated at least 4" from the tank bottom (6" for 12' diameter tanks).

## 3. EXECUTION

### 3.1. Installation and Testing

- 3.1.1. Fiberglass underground tanks must be tested and installed according to the current installation instructions provided with the tank (refer to Containment Solutions Pub. No. INST 6001). Tanks are installed with pea gravel or crushed stone as specified in current installation instructions. Containment Solutions' tanks are intended for storing products listed in the warranty; any other products not listed in the warranty must be approved in advance by Containment Solutions.

## 4. LIMITED WARRANTY

### 4.1. Limited Warranty

- 4.1.1. Warranty shall be Containment Solutions limited warranty in effect at time of delivery.

MARK	QTY	SIZE	EQUIPMENT LISTING	MARK	QTY	SIZE	EQUIPMENT LISTING	MARK	QTY	SIZE	EQUIPMENT LISTING
A	1	8'	HYDROSTATIC DOUBLE WALL COMPARTMENT TANK	I	1*		INVENTORY & LEAK DETECTION PANEL	Q	2*		OVERFILL PREVENTION VALVE
B	2	48"	SINGLE WALL CONTAINMENT COLLAR	J	4*		CONTAINMENT COLLAR SENSOR	R	2*	4"	DROP TUBE
C	2	48"	SW PTS WATER TIGHT TURBINE SUMP	K	1*		FUEL DISPENSER w/UDC	S	4*	4"	BALL FLOAT ASSEMBLY
D	2	42"	SINGLE WALL CONTAINMENT COLLAR	L	2*		TANK INVENTORY GAUGE	T	2*	36"	WATERTIGHT MANHOLE
E	2	42"	SW PTS FILL/VAPOR SUMP	M	1*		HYDROSTATIC TANK RESERVOIR SENSOR	U	*	3"x2"	DOUBLE WALL FRP PIPE
F	6		HOLD DOWN SPLIT STRAP ASSEMBLY	N	2*	36"	MULTI-PORT SPILL CONTAINMENT MANHOLE	V	2*	4"	EXTRACTOR HOUSING w/CAP
G	4	12'	12"x 12" CONCRETE DEADMAN ANCHORS	O	2*	2"	PRIMARY TANK VENT	W	1*	18"	MANHOLE
H	2*		SUBMERSIBLE PUMP w/LEAK DETECTION	P	1*	2"	SUMP VENTS -- (MANIFOLDED)	X	1*		PUMP CONTROL PANEL

NOTE: \* SUPPLIED BY OTHERS

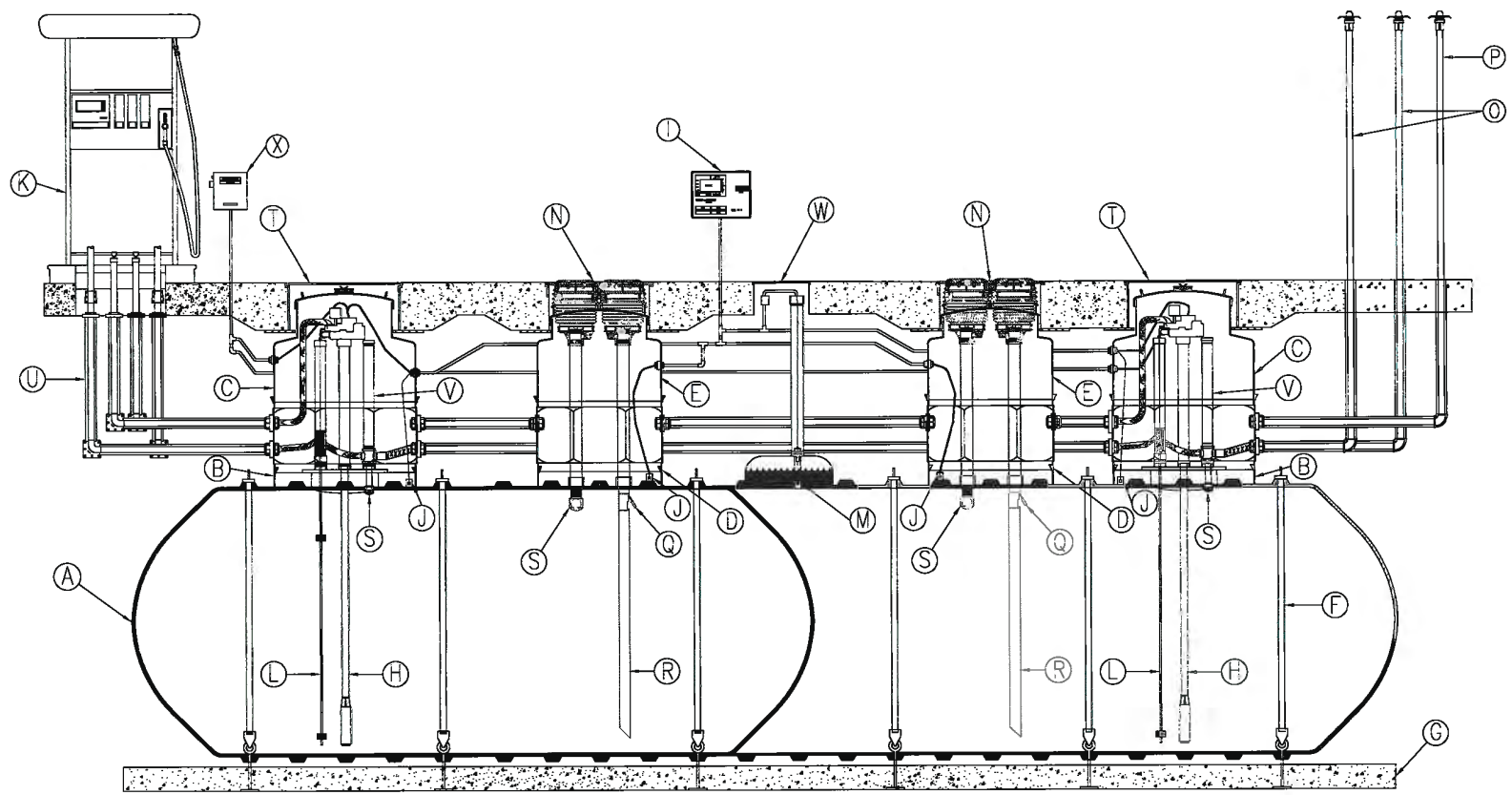

TYPICAL PETROLEUM ILLUSTRATION DRAWING  
 (8') 6,000 / 6,000 DOUBLE-WALL COMPARTMENT TANK  
 W / SINGLE-WALL TURBINE AND FILL / VAPOR SUMPS



THIS DIAGRAM IS THE PROPERTY OF CONTAINMENT SOLUTIONS, INC., AND IS FOR ILLUSTRATION PURPOSES ONLY. IT IS NOT TO BE RELIED UPON FOR ANY OTHER PURPOSE. NO WARRANTY OF MERCHANTABILITY OR FITNESS FOR A PARTICULAR PURPOSE OR OF ANY OTHER KIND, EXPRESSED OR IMPLIED IS HEREBY MADE. COPYRIGHT © 2009 CONTAINMENT SOLUTIONS, INC. ALL RIGHTS RESERVED.