

9 ELKS LANE
 POUGHKEEPSIE, NEW YORK 12601
 TEL (845) 454-3411
 FAX (845) 473-1962

CPLteam.com

ARCHITECTURE ■ ENGINEERING ■ PLANNING

REV. No.	DESCRIPTION	DATE	BY
----------	-------------	------	----

TYPICAL SANITARY SEWER LATERAL INSTALLATION

TOWN OF WAPPINGER

DUTCHESS COUNTY, NY

PLAN VIEW

DATE	SCALE	DESIGNED BY: JFL/PEH	FILE No.
01-06-21	N.T.S.	DRAWN BY: GS	W21500.20
		CHECKED BY: RJG	

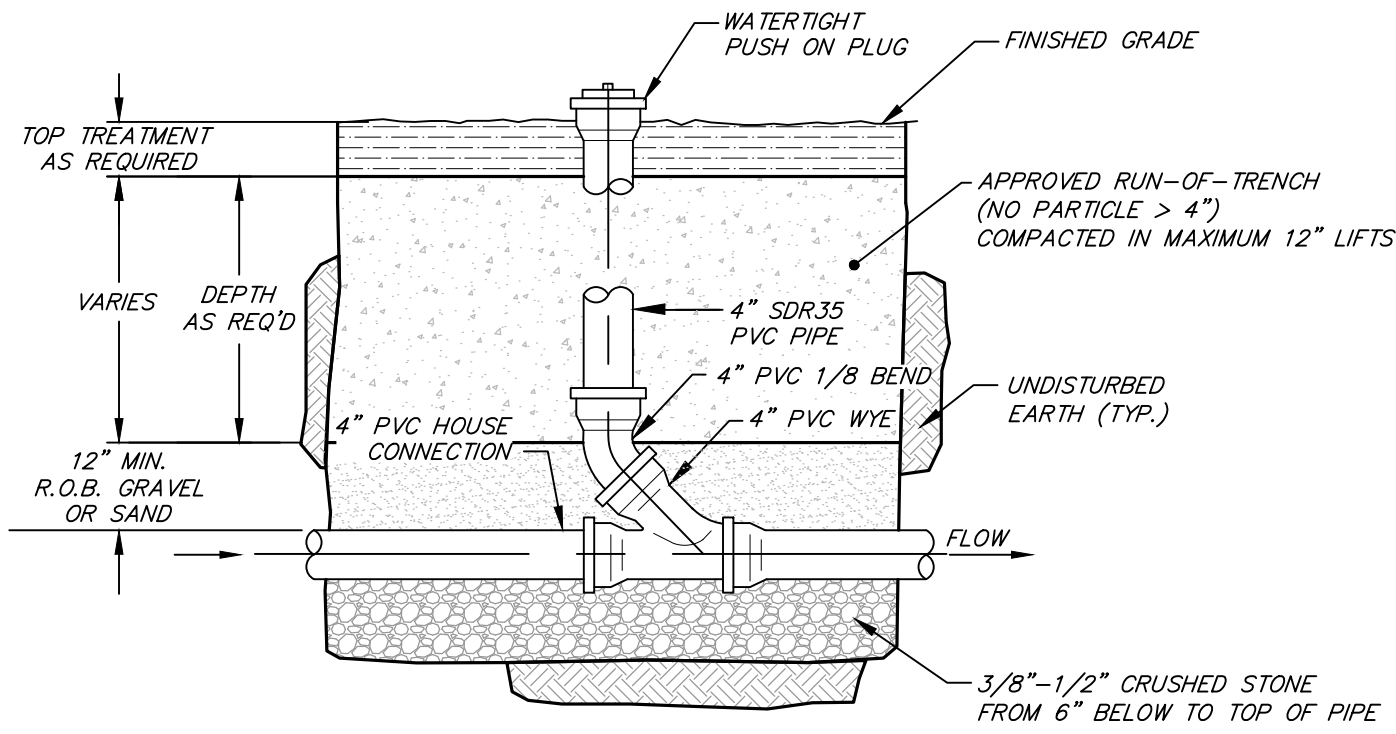

CLEANOUT DETAIL

SEE CONSTRUCTION NOTES ON SHEET 3 OF 3.

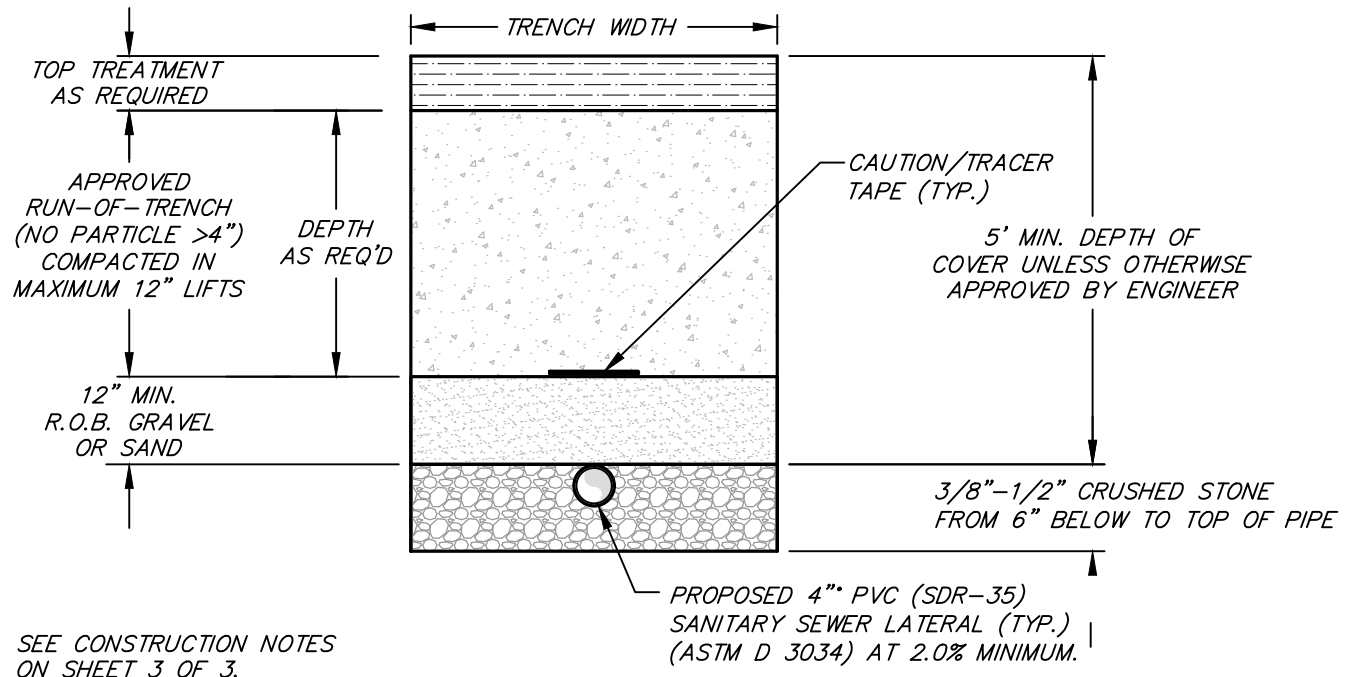

TRENCH SECTION VIEW

SEE CONSTRUCTION NOTES ON SHEET 3 OF 3.



9 ELKS LANE
POUGHKEEPSIE, NEW YORK 12601
TEL (845) 454-3411
FAX (845) 473-1962

CPLteam.com
ARCHITECTURE ■ ENGINEERING ■ PLANNING

REV. No.	DESCRIPTION	DATE	BY
TYPICAL SANITARY SEWER LATERAL INSTALLATION			
TOWN OF WAPPINGER		DUTCHESS COUNTY, NY	

SECTION VIEW

DATE	SCALE	DESIGNED BY: JFL/PEH	FILE No.
01-06-21	N.T.S.	DRAWN BY: GS	W21500.20
		CHECKED BY: RJG	

CONSTRUCTION NOTES:

1. INSTALLATION OF AN INDIVIDUAL RESIDENTIAL SANITARY SEWER LATERAL SHALL REQUIRE THAT A PERMIT BE OBTAINED FROM THE TOWN OF WAPPINGER BUILDING DEPARTMENT.
2. THE APPLICANT SHALL BE REQUIRED TO MAKE ALL ARRANGEMENTS WITH THE TOWN OF WAPPINGER BUILDING DEPARTMENT, INCLUDING SCHEDULING OF ALL SITE INSPECTIONS. ANY WORK PERFORMED WITHOUT PROPER INSPECTION WILL NEED TO BE REDONE IN THE PRESENCE OF THE TOWN INSPECTOR. ANY WORK WITHIN TOWN ROAD RIGHT-OF-WAY MUST BE SCHEDULED IN ADVANCE WITH THE TOWN HIGHWAY SUPERINTENDENT.
3. NO TRENCH SHALL BE BACKFILLED UNTIL SUCH TIME AS THE TOWN INSPECTOR HAS HAD ADEQUATE TIME TO INSPECT EACH PIPE JOINT.
4. THE APPLICANT SHALL BE RESPONSIBLE FOR CONTACTING THE UNDERGROUND FACILITIES PROTECTION ORGANIZATION AT 1-800-962-7962, FOR AN EXISTING UTILITY MARK OUT PRIOR TO THE START OF ANY EXCAVATION.
5. ALL SANITARY SEWER PIPING SHALL BE A MINIMUM 4 INCH DIAMETER P.V.C. SDR-35 (ASTM D 3034).
6. ALL SANITARY SEWER LATERAL PIPING SHALL BE LAID AT A MINIMUM GRADE OF 2.0% (1/4" PER FOOT).
7. THE APPLICANT SHALL BE RESPONSIBLE FOR INSTALLING CLEANOUTS ON THE SEWER LATERAL AT ALL BENDS, AND AT A MAXIMUM SPACING OF 75' ON ALL STRAIGHT RUNS UNLESS OTHERWISE APPROVED BY THE ENGINEER. THE MAXIMUM PIPE BEND SHALL BE 1/8. NO 1/4 BENDS SHALL BE PERMITTED.
8. THE APPLICANT SHALL BE RESPONSIBLE FOR COMPLYING WITH ALL APPLICABLE OSHA REGULATIONS FOR TRENCHES IN EXCESS OF 5 FEET DEPTH. ALL DITCHES/TRENCHES SHALL BE ADEQUATELY DEWATERED PRIOR TO PIPE INSTALLATION. PIPE SHALL NEVER BE LAID IN ANY GROUNDWATER CONDITION, WHATSOEVER. THE OPEN END OF THE SEWER LATERAL SHALL BE KEPT PLUGGED AT ALL TIMES, AND SHALL NOT BE USED TO DEWATER THE TRENCH.
9. IF UNSUITABLE AND/OR UNSTABLE SUBBASE CONDITIONS ARE ENCOUNTERED, ADDITIONAL CRUSHED STONE BEDDING MATERIAL IN EXCESS OF THE 6 INCH MINIMUM DEPTH SHALL BE PLACED PRIOR TO PIPE INSTALLATION.
10. THERE SHALL BE NO ROOF DRAINS, FOOTING DRAINS, SUMP PUMPS OR ANY OTHER EXTRANEIOUS SOURCE OF FLOW TIED INTO THE SANITARY SEWER LATERAL.
11. THE EXISTING SEPTIC TANK (IF ANY) SHALL BE PUMPED OUT, THE TOP AND BOTTOM BROKEN OUT, AND FILLED WITH COMPACTED CLEAN SAND OR STONE FILL IN ACCORDANCE WITH ALL APPLICABLE DUTCHESS COUNTY HEALTH DEPARTMENT CODES.
12. THE LATERAL CONNECTION TO THE EXISTING HOUSE SOIL LINE SHALL BE MADE APPROXIMATELY 5 FEET FROM THE OUTSIDE EDGE OF THE HOUSE, WITH A "PROFLEX" SERIES 3000 COUPLING AS MANUFACTURED BY FERNCO, OR APPROVED EQUAL. USE CONCRETE AROUND THE FERNCO FOR SUPPORT. FOR NEW BUILDING CONSTRUCTION, A PIPE SLEEVE IS REQUIRED THROUGH THE FOUNDATION WALL FOR THE LATERAL.
13. ALL WORK SHALL BE PERFORMED IN ACCORDANCE WITH ACCEPTED STANDARDS AND PRACTICES TO THE SATISFACTION OF THE TOWN BUILDING INSPECTOR, THE TOWN ENGINEER, THE SEWER SYSTEM OPERATOR, AND THE DUTCHESS COUNTY HEALTH DEPARTMENT.
14. ALL SEWER LATERALS SHALL BE 10 FEET MINIMUM FROM EXISTING WATER LINES, WITH 18 INCH MINIMUM SEPARATION AT ALL CROSSINGS. SEWER LATERALS SHALL BE 25 FEET MINIMUM FROM SURROUNDING WELLS. SEWER LINES SHALL CROSS BENEATH WATER LINES WHEN POSSIBLE. IN EXTRAORDINARY CIRCUMSTANCES, SEWER AND WATER SERVICE LINES MAY BE CONSTRUCTED IN THE SAME TRENCH IF APPROVED IN ADVANCE BY THE TOWN AND CONSTRUCTED TO THE REQUIREMENTS OF THE N.Y.S. BUILDING AND PLUMBING CODES.

UTILITY LINES, INCLUDING SEWER AND WATER SERVICES, MUST BE SEPARATED BY A MINIMUM OF 10 FEET UNLESS BENCHED IN ACCORDANCE WITH N.Y.S. PLUMBING CODE. BENCHED PIPES SHALL HAVE 18 INCH MINIMUM HORIZONTAL AND VERTICAL SEPARATION. WATER LINES SHALL ALWAYS BE INSTALLED ABOVE SANITARY SEWER LINES.
15. ALL HOUSEHOLD WASTEWATER SHALL BE DISCHARGED TO THE TOWN SEWER SYSTEM, INCLUDING SEEPAGE PITS/DRYWELLS, ETC. (E G. WASHING MACHINES). ALL SUCH SEEPAGE PITS/DRYWELLS SHALL BE ABANDONED SIMILARLY TO THE SEPTIC TANK (I.E. PUMPED AND FILLED). INTERNAL AND/OR EXTERNAL PIPING MODIFICATIONS MAY BE REQUIRED TO CONNECT THEM TO THE CENTRAL SEWER FACILITIES.



9 ELKS LANE
POUGHKEEPSIE, NEW YORK 12601
TEL (845) 454-3411
FAX (845) 473-1962

CPLteam.com

ARCHITECTURE ■ ENGINEERING ■ PLANNING

REV. No.	DESCRIPTION	DATE	BY
TYPICAL SANITARY SEWER LATERAL INSTALLATION			
TOWN OF WAPPINGER		DUTCHESS COUNTY, NY	

NOTES

DATE	SCALE	DESIGNED BY: JFL\THH	FILE No.
01-06-21	N.T.S.	DRAWN BY: ZRS	W21500.20
		CHECKED BY: RJG	